

**Componenti per l'allestimento  
di cassoni  
con sponde in alluminio**

## Indice

Cerniere per sponde in alluminio	pag. 52
Cerniere per sponde a doppia apertura	pag. 57
Chiusure incassate	pag. 60
Chiusure esterne	pag. 61
Tendicatena	pag. 63
Minilock	pag. 65
Montanti serie BB2-BB4	pag. 69
Montanti per cassoni fissi serie BB5	pag. 81
Montanti per cassoni fissi serie BB10	pag. 82
Montanti per cassoni fissi serie "CP"	pag. 84
Testate zincate	pag. 87
Montanti kinnegrip K4	pag. 88
Montanti kinnegrip K20	pag. 90
Montanti H2800 serie BB7	pag. 94
Montanti per ribaltabili	pag. 96
Sovramontanti	pag. 102
Montanti per chiusura sponde posteriori	pag. 105
Monoprofilo in alluminio	pag. 106
Profili in alluminio serie TS-TR1	pag. 109
Profili in alluminio serie TR6	pag. 119
Profili in alluminio serie TR30	pag. 120
Profili in alluminio serie TR5	pag. 122
Profili sovrasponde	pag. 124
Profili per isotermici	pag. 125
Profili per pianali	pag. 127
Lamiere in alluminio	pag. 129
Lamiere in acciaio inox fiorettato	pag. 131
Profili aggancio cricchetto	pag. 132
Profili tenditelone	pag. 133
Longherine	pag. 134
Multistrato	pag. 136
Viti per multistrato	pag. 137
Rivetti	pag. 138
Tappi per profili sovrasponde	pag. 139

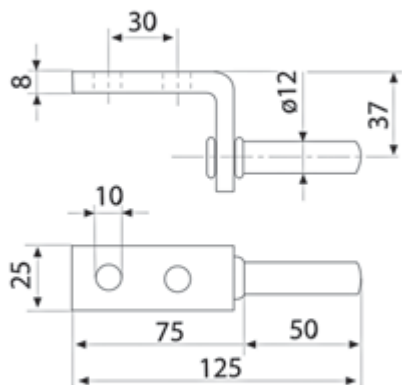

Art.10.3010

Perno

kg 0,20

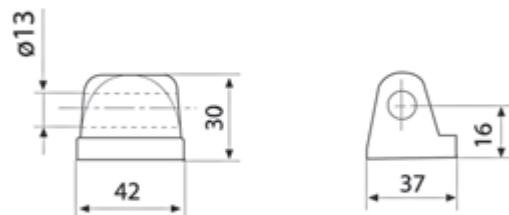

Art.10.3002

Cerniera

kg 0,18

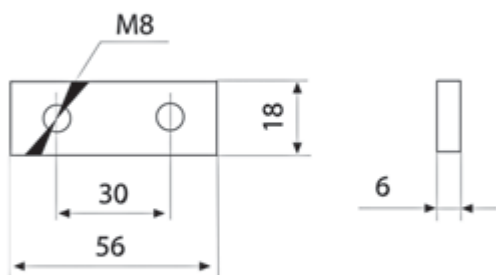

Art.10.3004

Plastrina

kg 0,04

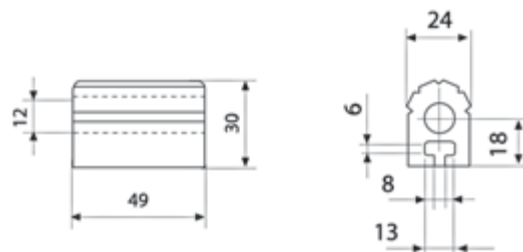

Art.10.3046

Cerniera in alluminio

kg 0,05

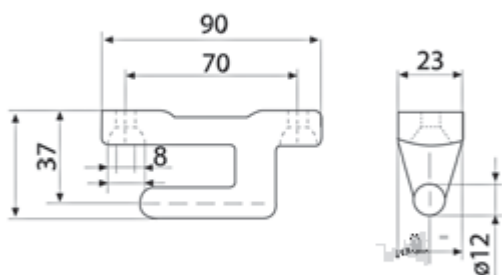

**Art.10.3020**  
 Perno tir piccolo zincato kg 0,23

**Art.10.3026**  
 Perno tir piccolo inox kg 0,23

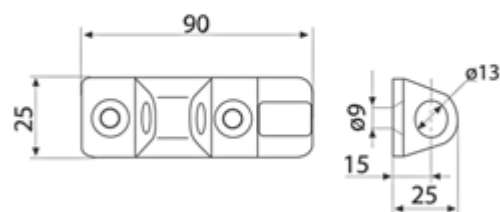

**Art.10.3022**  
 Cerniera tir piccola grezza kg 0,21

**Art.10.3028**  
 Cerniera tir piccola inox kg 0,21

**Art.10.3023**  
 Cerniera tir piccola zincata e forata kg 0,21

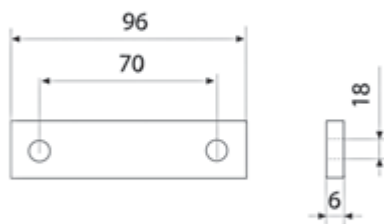

**Art.10.3024**  
 Piastrina kg 0,08

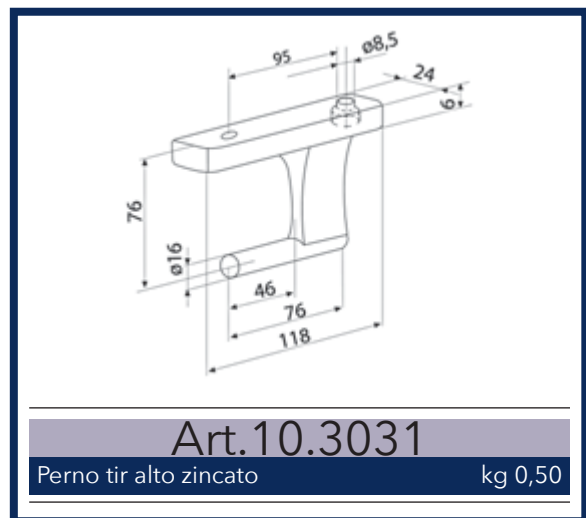
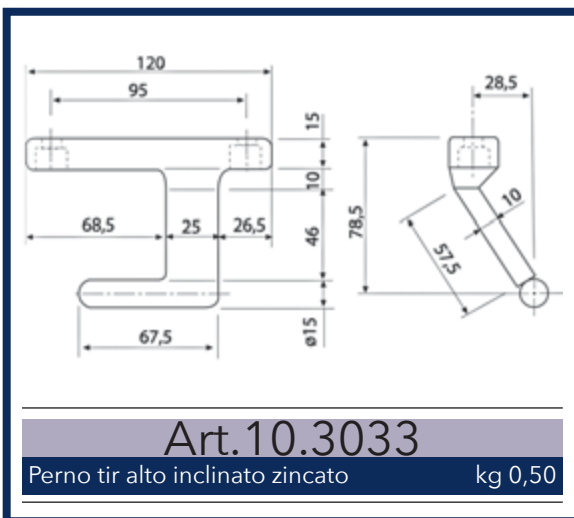
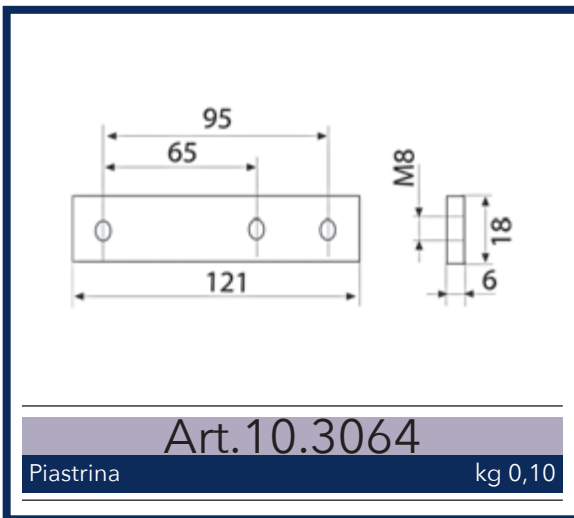
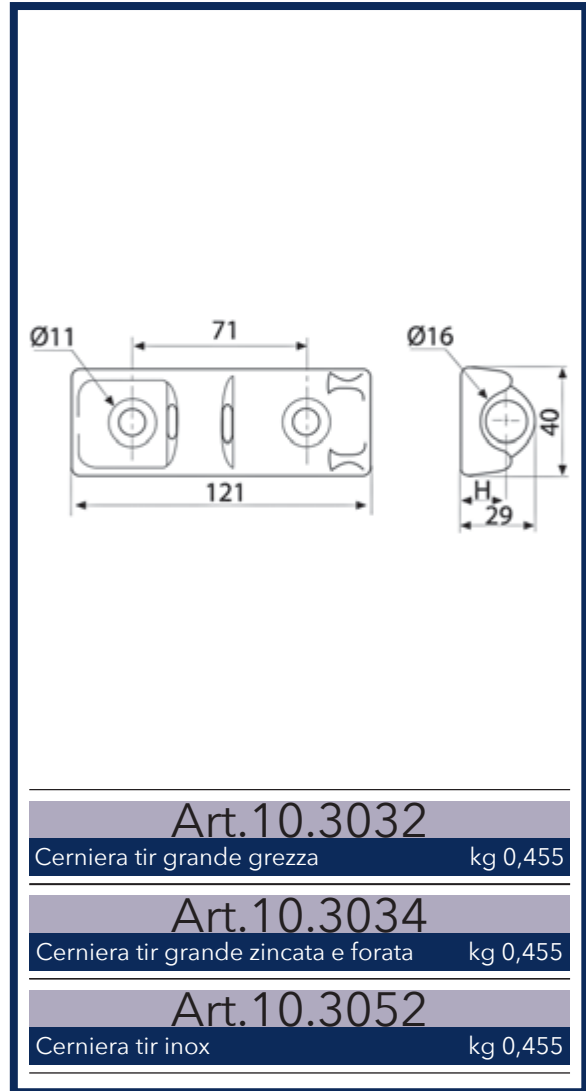
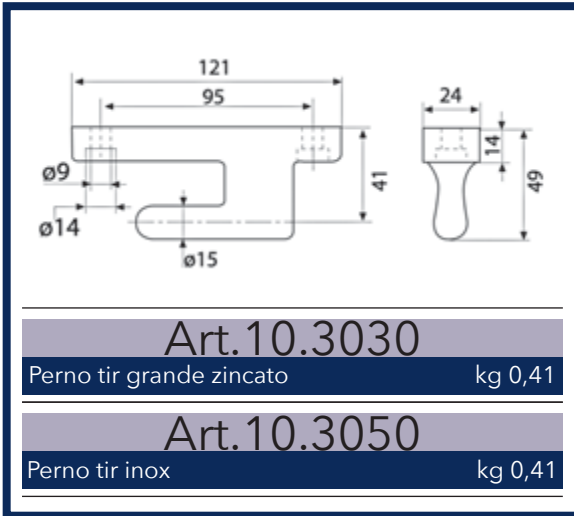

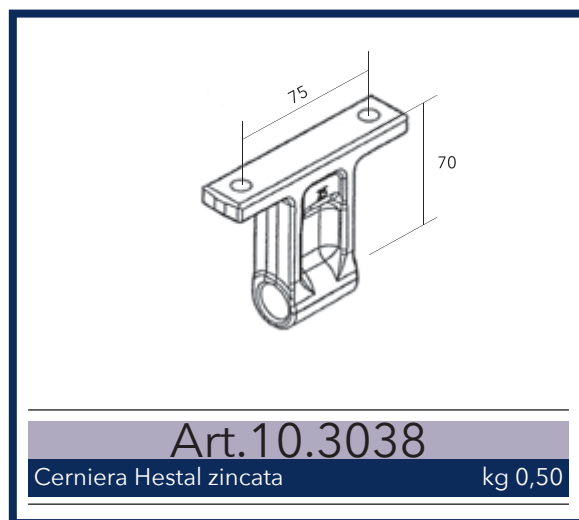
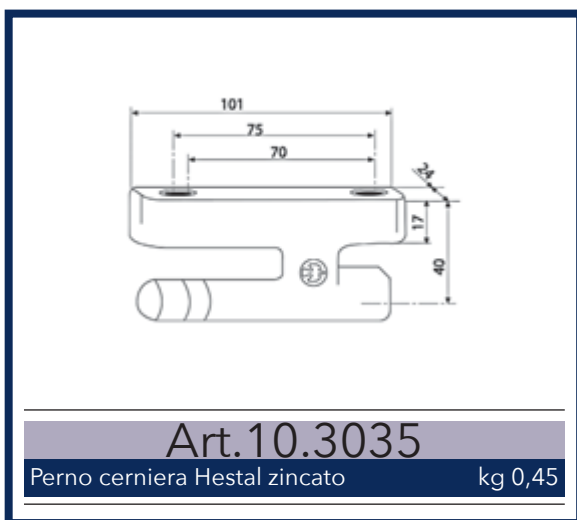
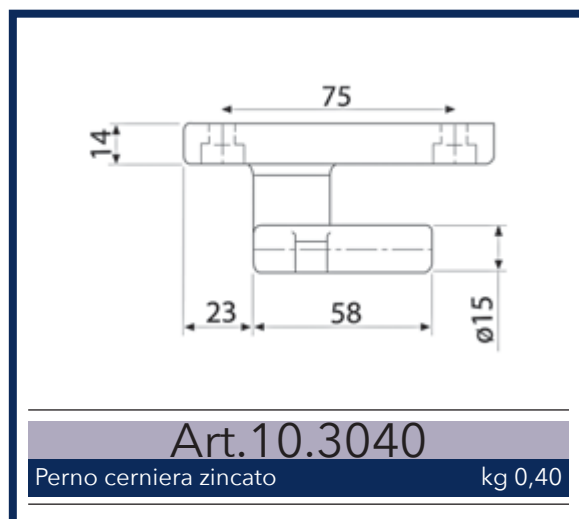
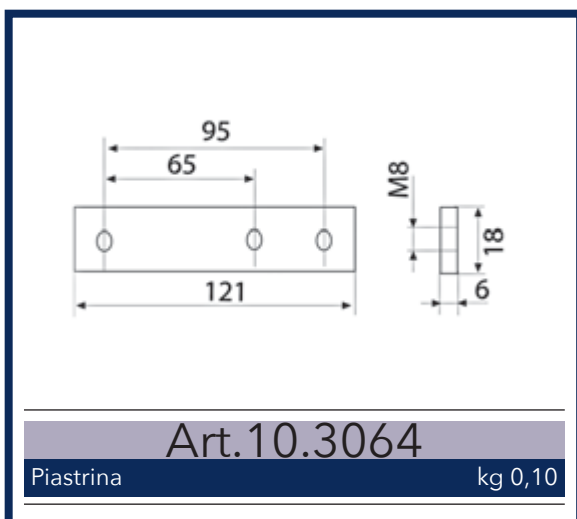
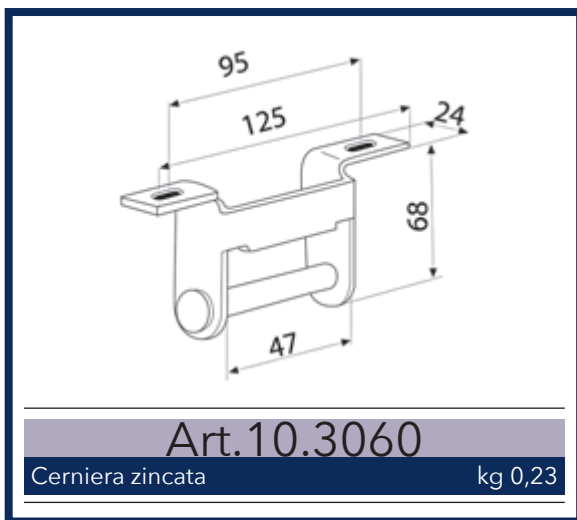

CERNIERE PER SPONDE IN ALLUMINIO

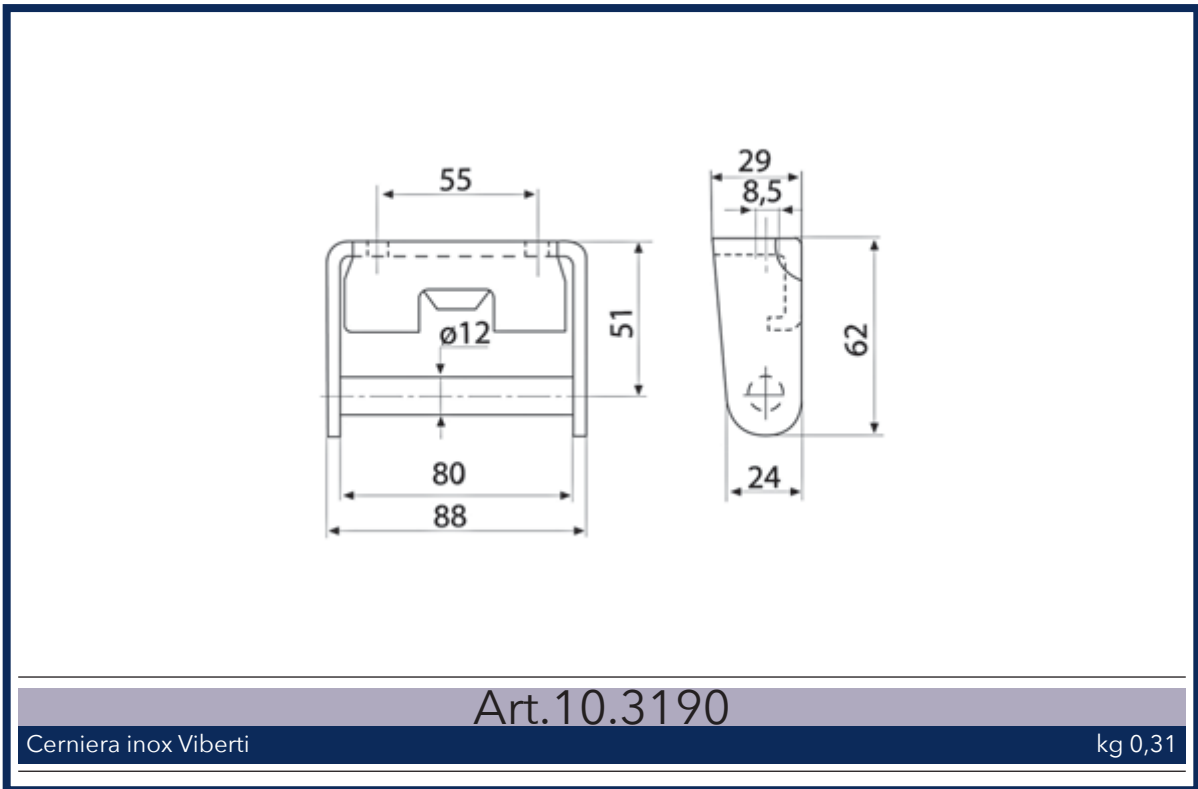
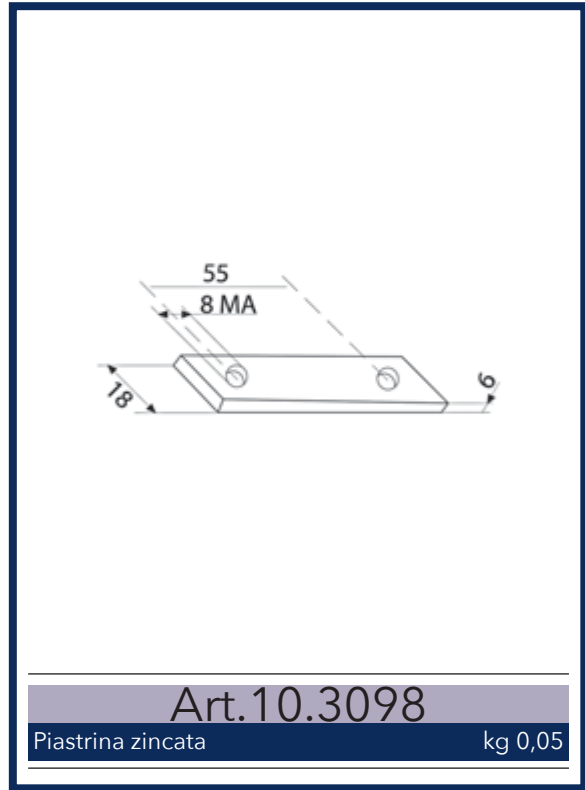
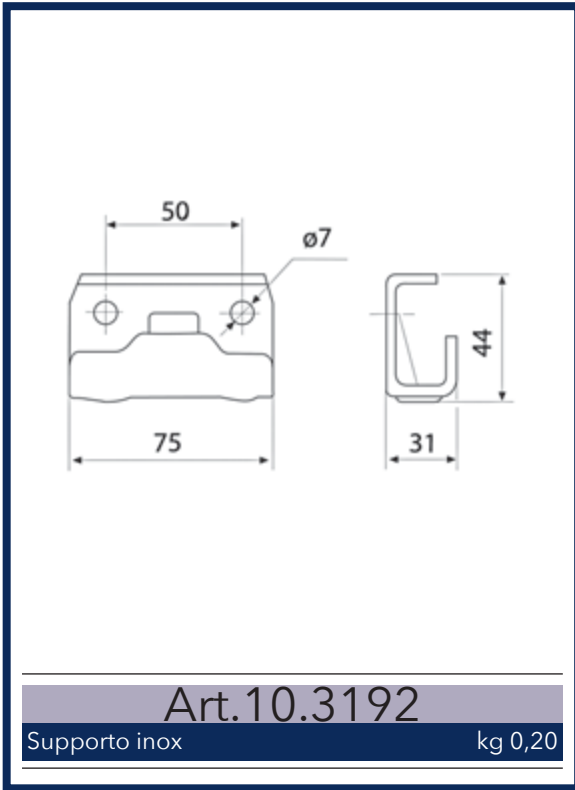

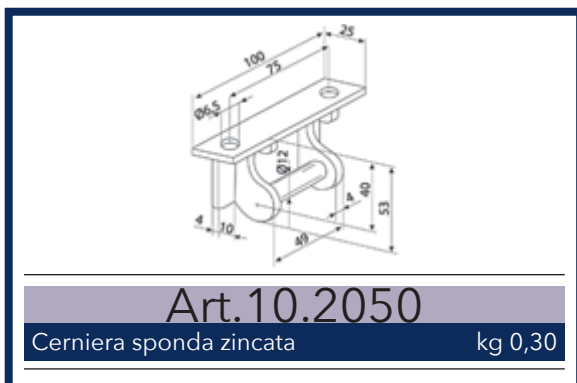

**Art. 10.2050**  
 Cerniera sponda zincata kg 0,30

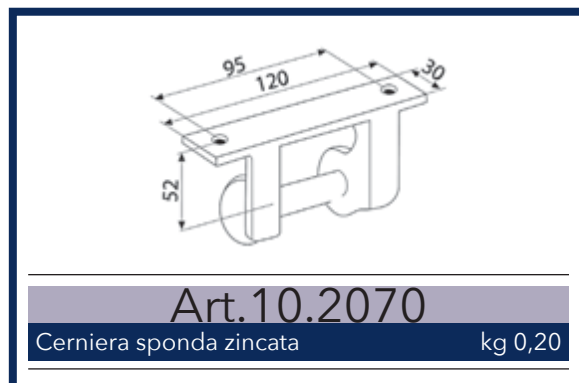

**Art. 10.2070**  
 Cerniera sponda zincata kg 0,20

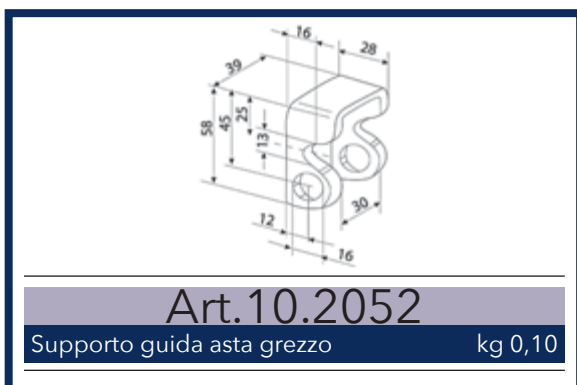

**Art. 10.2052**  
 Supporto guida asta grezzo kg 0,10



**Art. 10.2072**  
 Supporto guida asta grezzo kg 0,12

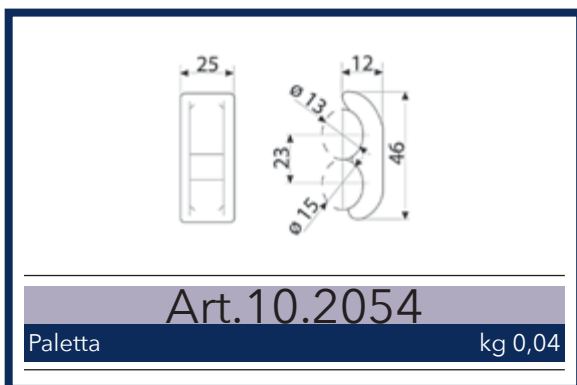

**Art. 10.2054**  
 Paletta kg 0,04

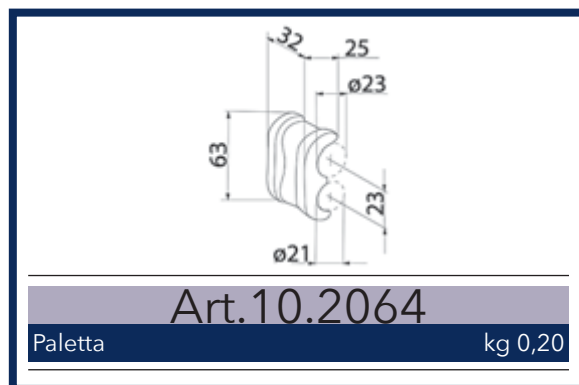

**Art. 10.2064**  
 Paletta kg 0,20

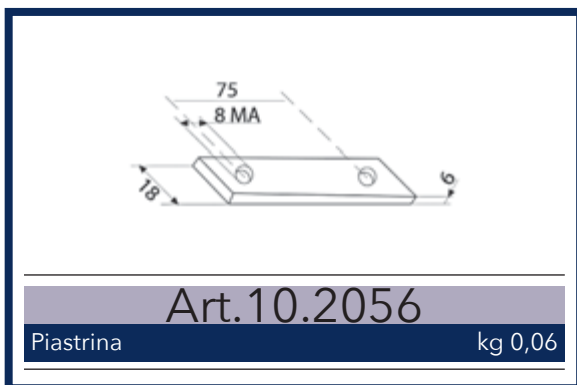

**Art. 10.2056**  
 Piastrina kg 0,06

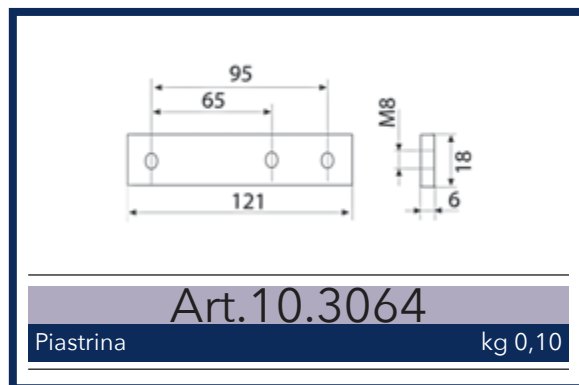

**Art. 10.3064**  
 Piastrina kg 0,10

CERNIERE PER SPONDE IN ALLUMINIO A DOPPIA APERTURA



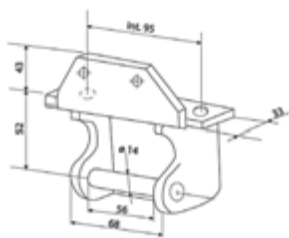

**Art.10.2030**  
 Cerniera sponda zincata kg 0,40

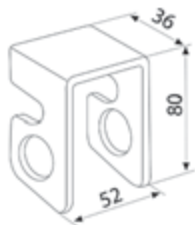

**Art.10.2072**  
 Supporto guida asta grezzo kg 0,12

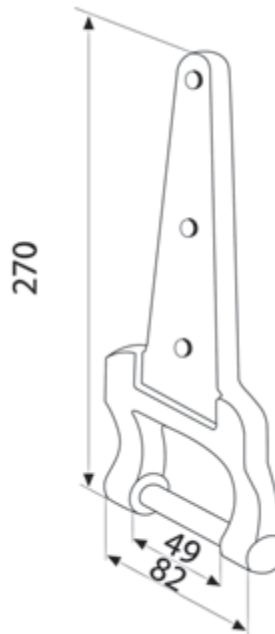

**Art.10.2060**  
 Cerniera sponda con fori zincata kg 0,75

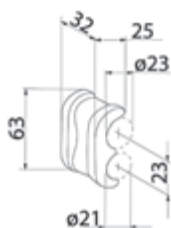

**Art.10.2064**  
 Paletta kg 0,20

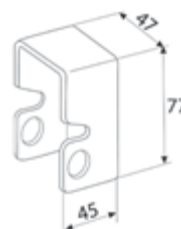

**Art.10.2062**  
 Supporto guida asta grezzo kg 0,20

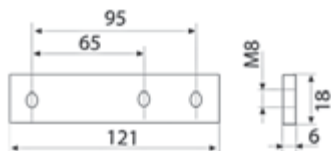

**Art.10.3064**  
 Piastrina kg 0,10

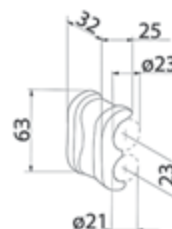

**Art.10.2064**  
 Paletta kg 0,20

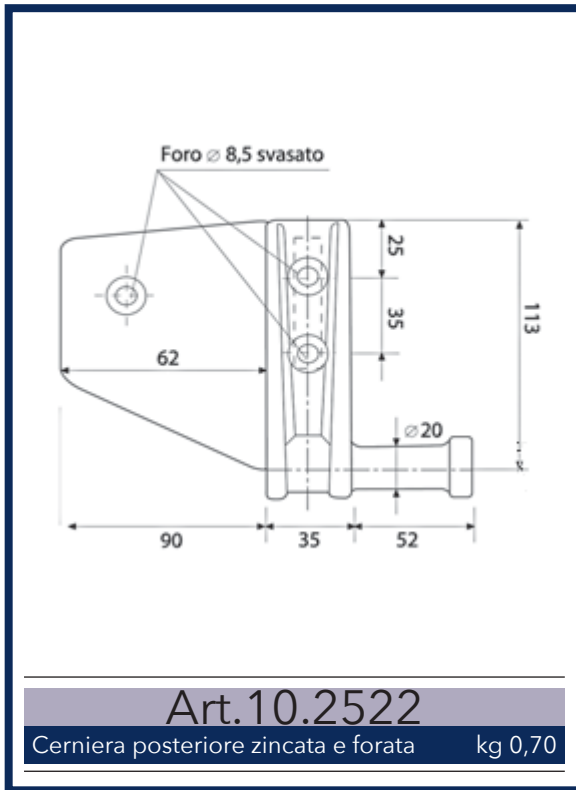

**Art. 10.2522**  
 Cerniera posteriore zincata e forata kg 0,70

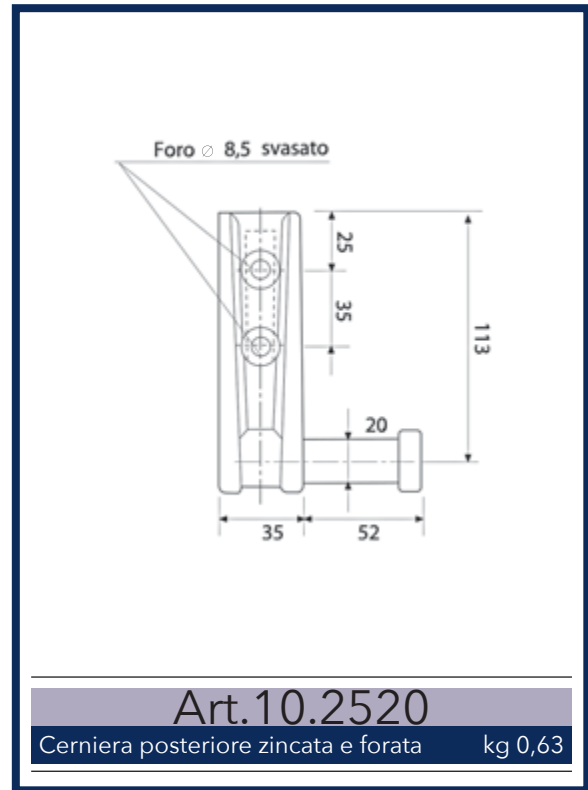

**Art. 10.2520**  
 Cerniera posteriore zincata e forata kg 0,63

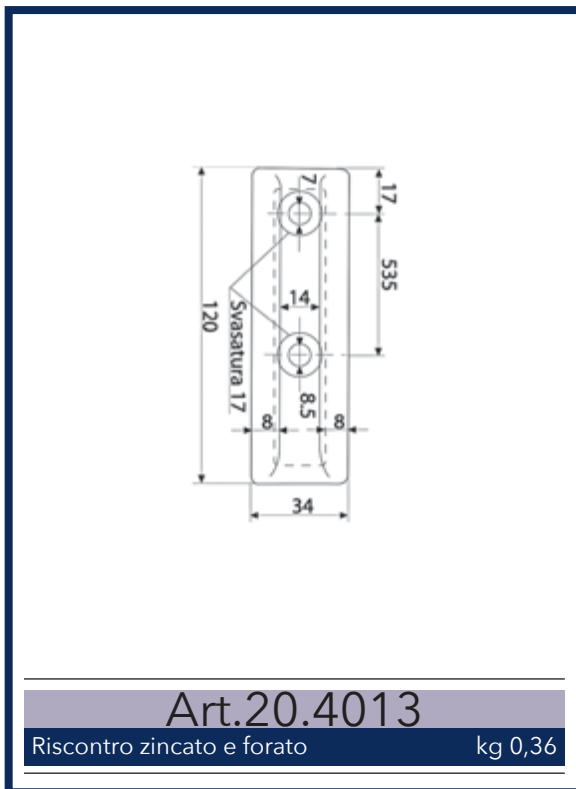

**Art. 20.4013**  
 Riscontro zincato e forato kg 0,36

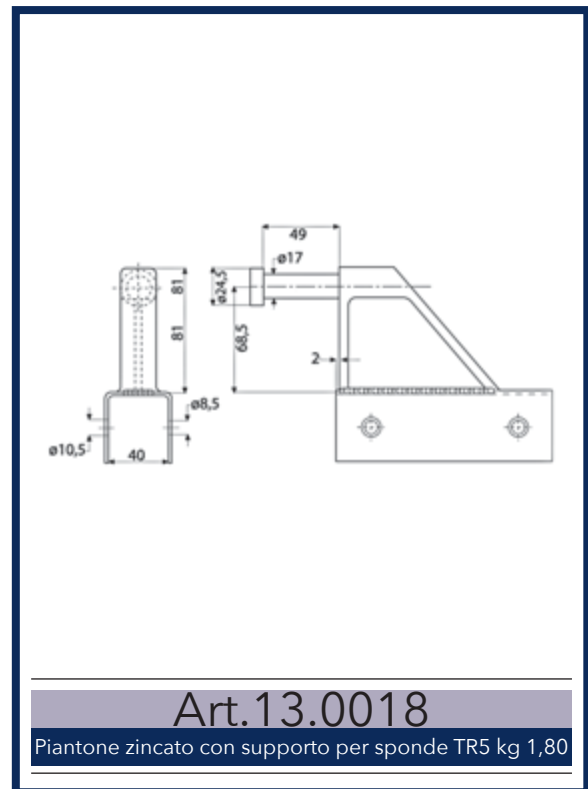

**Art. 13.0018**  
 Piantone zincato con supporto per sponde TR5 kg 1,80

CERNIERE PER SPONDE IN ALLUMINIO A DOPPIA APERTURA

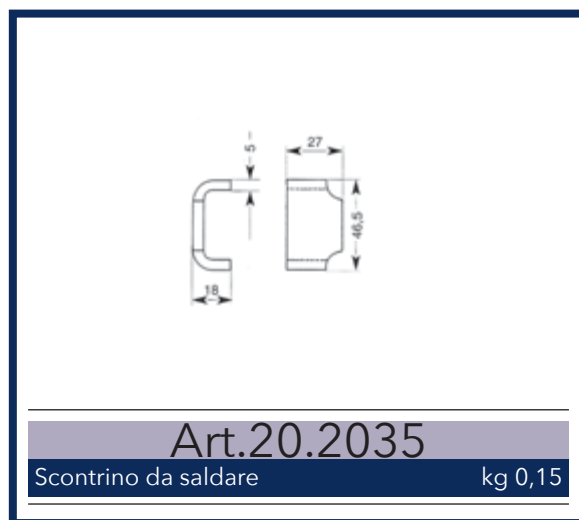
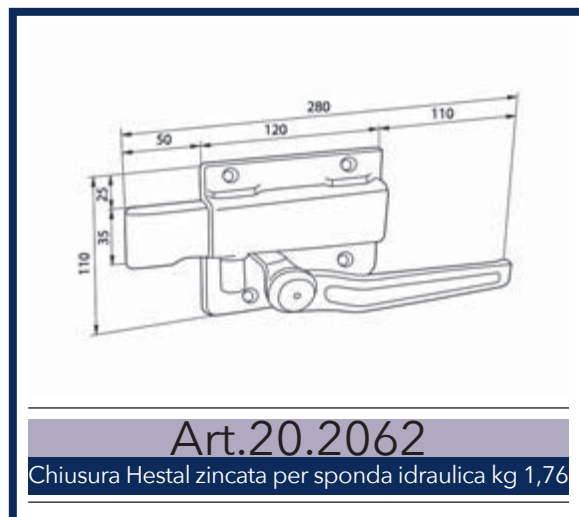
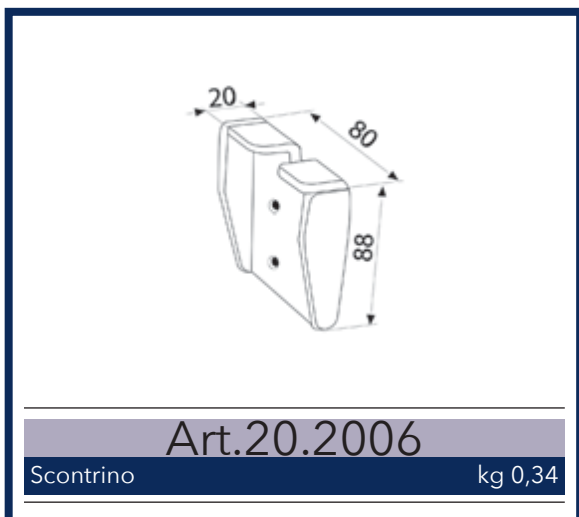
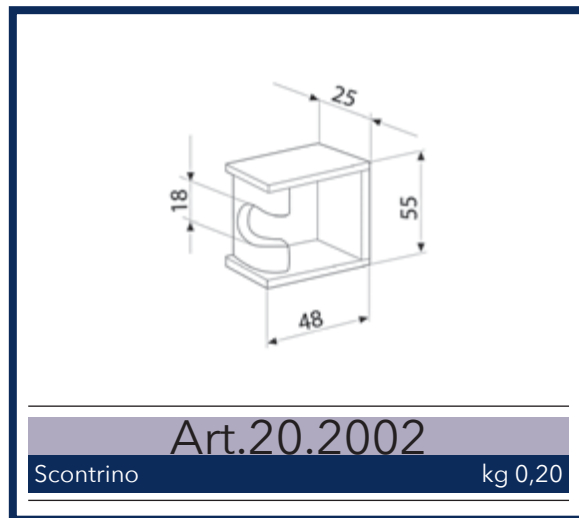
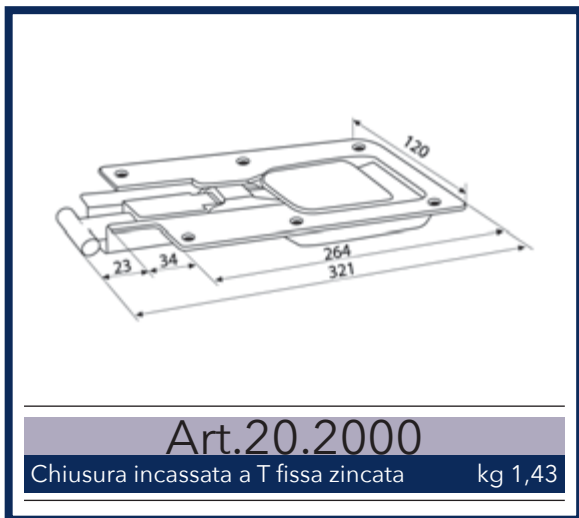

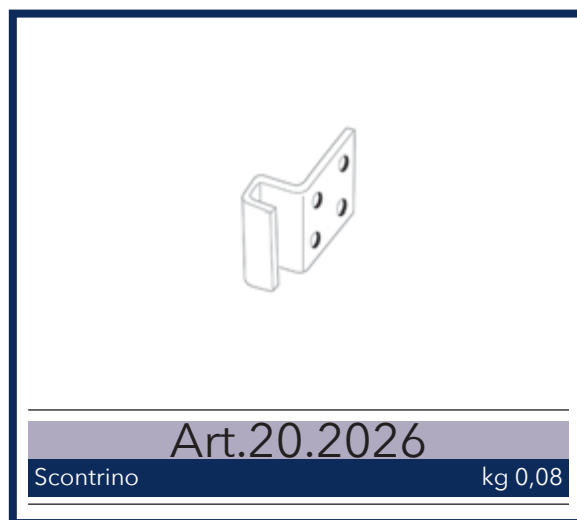
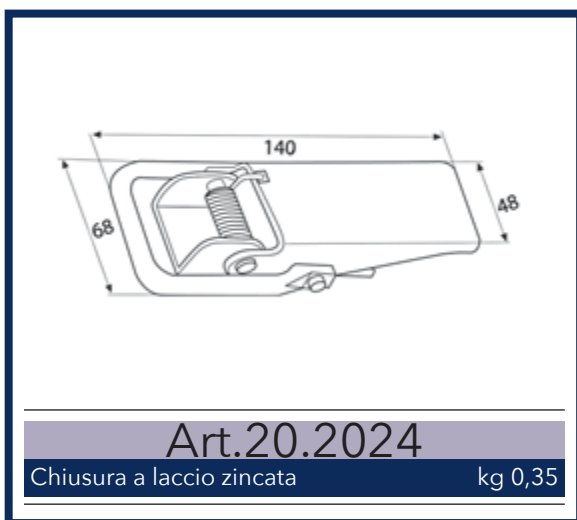
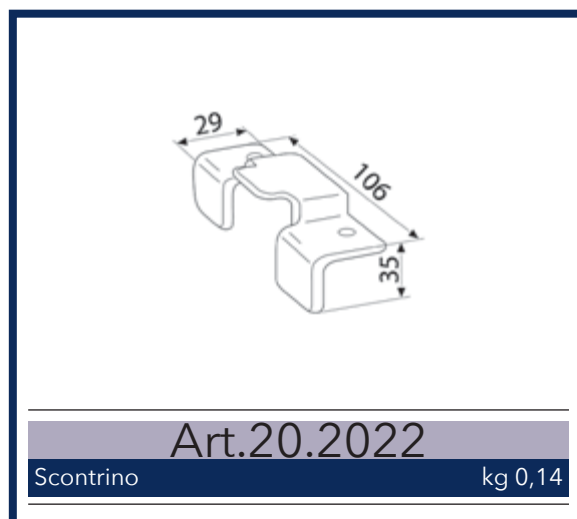
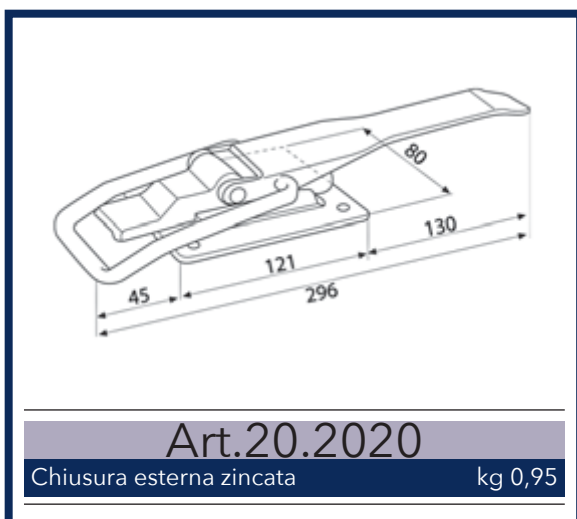
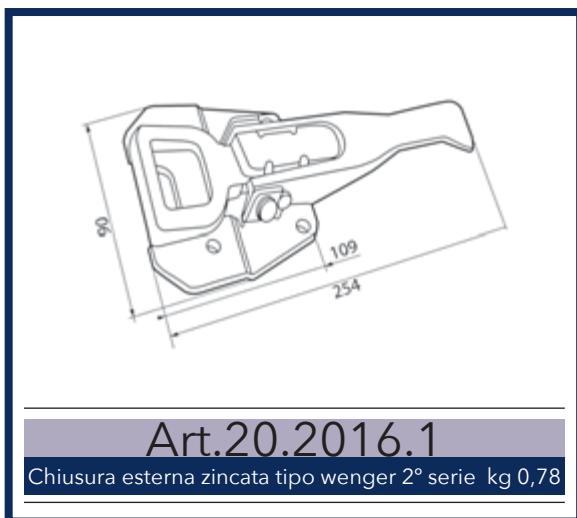

CHIUSURE PER SPONDE IN ALLUMINIO

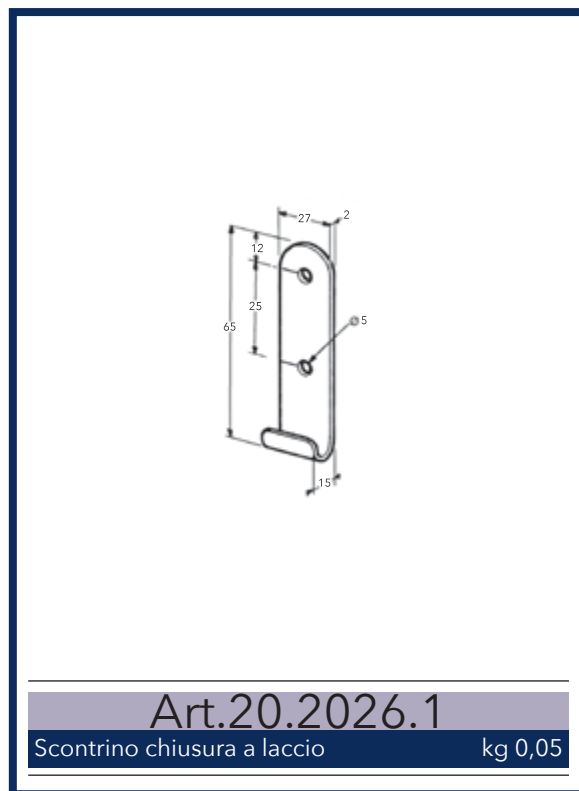
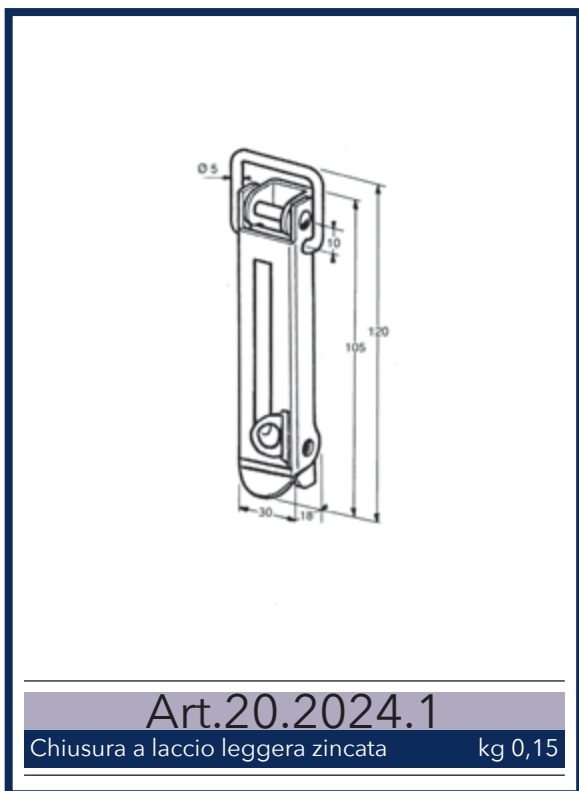
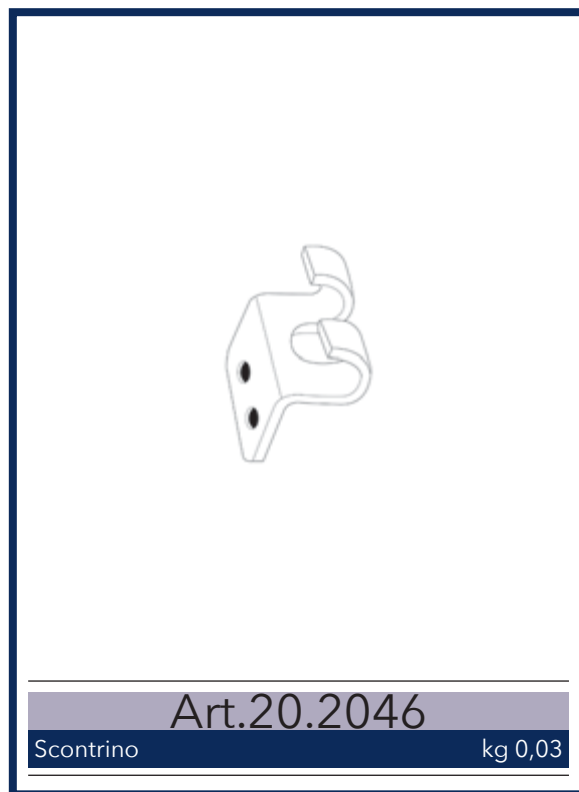
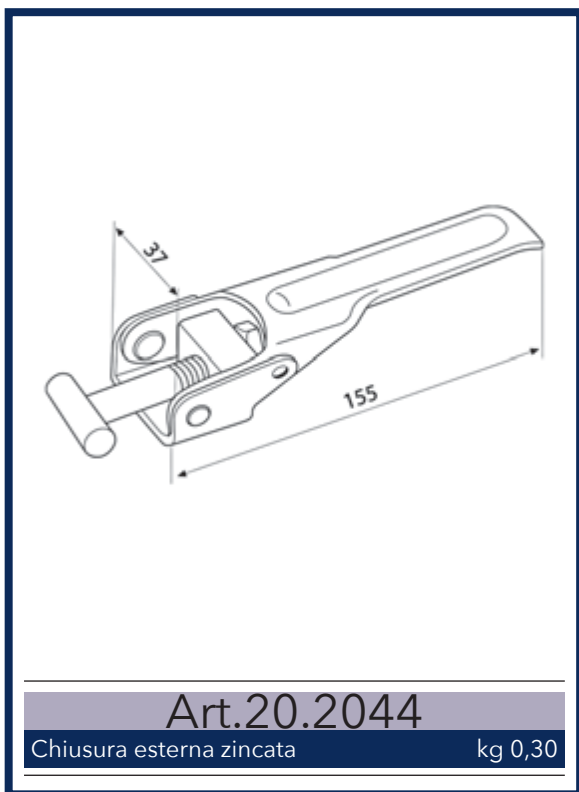

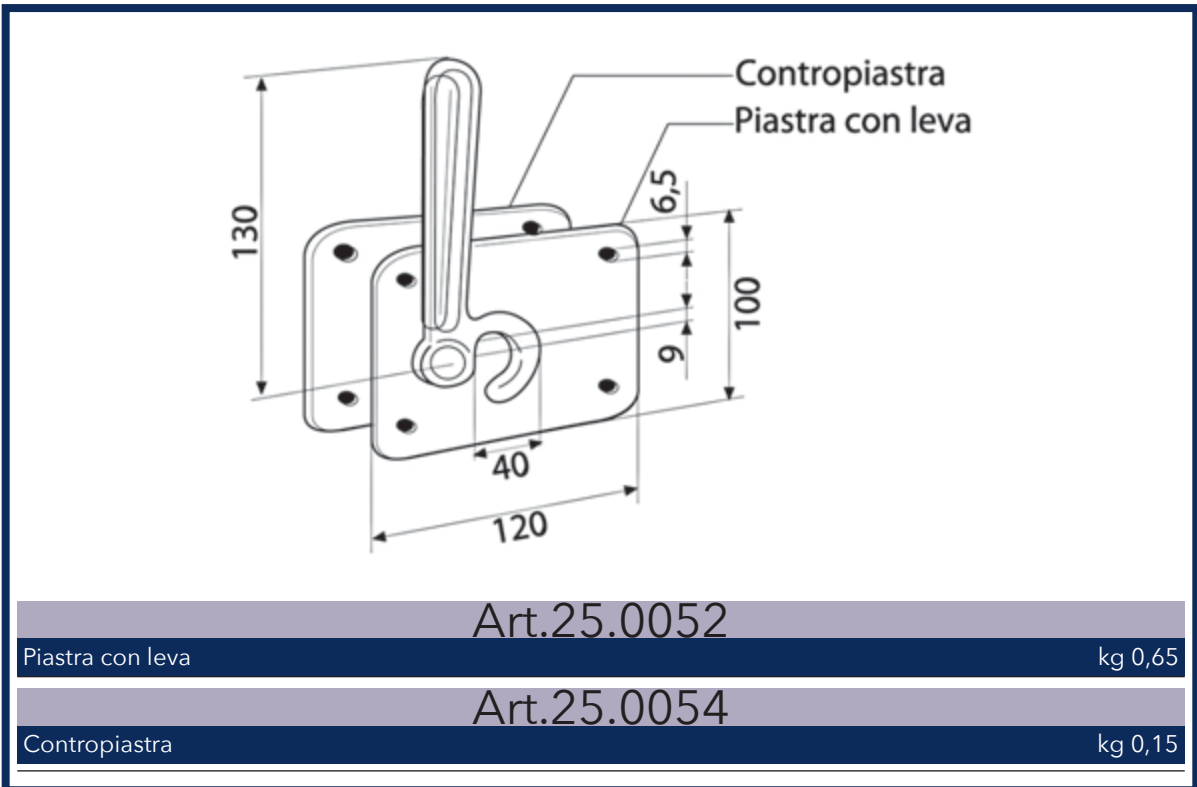
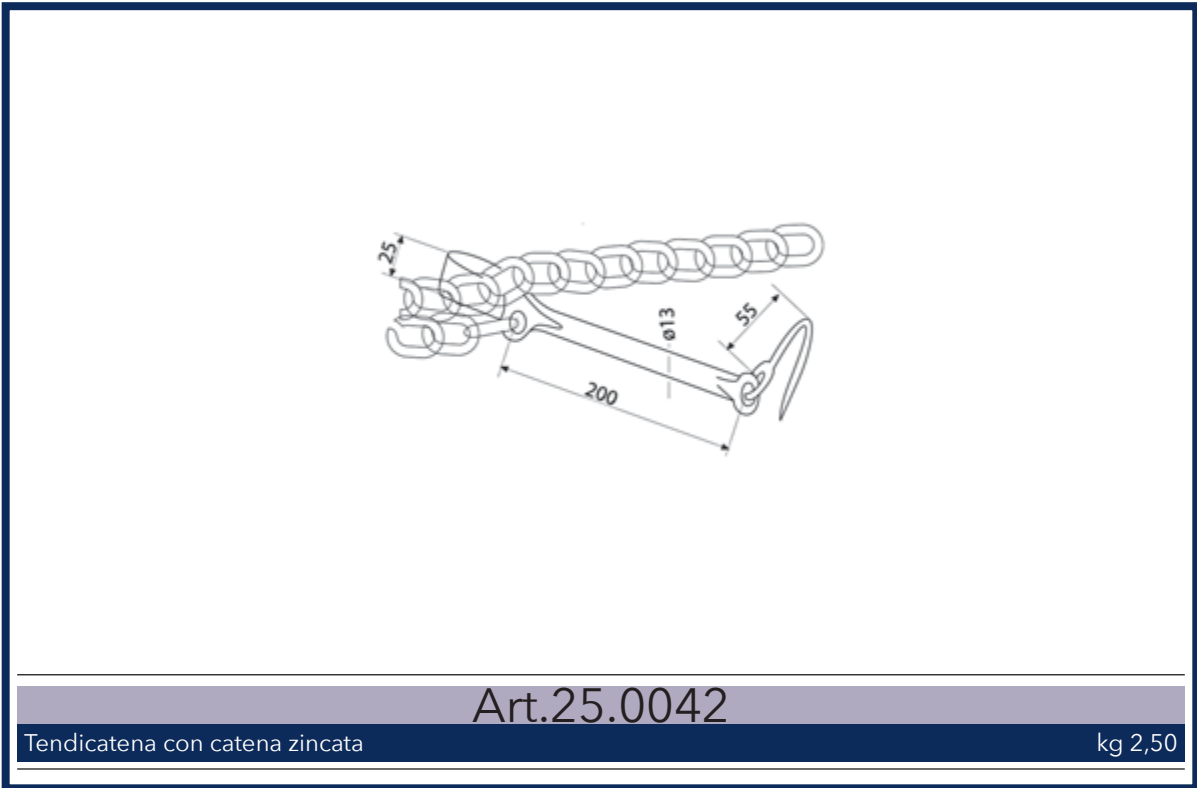

TENDICATENA

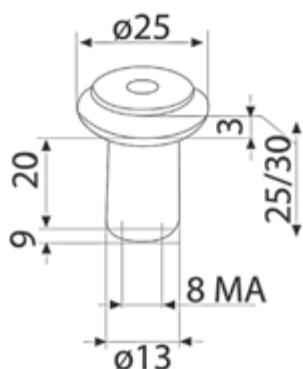

**Art.10.3082**

Bussola sponda in alluminio mm 25

**Art.10.3083**

Bussola sponda in alluminio mm 30

**Art.10.3082.1**

Bussola sponda zincata mm 25

**Art.10.3083.1**

Bussola sponda zincata mm 30

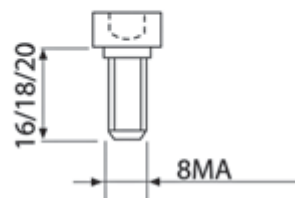

**Art.10.3091**

Vite brugola zincata mm 12x8

**Art.10.3085**

Vite brugola zincata mm 16x8

**Art.10.3087**

Vite brugola zincata mm 18x8

**Art.10.3088**

Vite brugola zincata mm 20x8

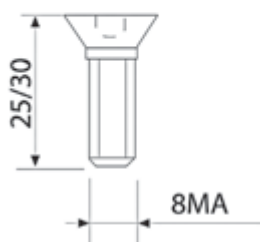

**Art.10.3084**

Vite brugola testa svasata mm 25x8

**Art.10.3084.1**

Vite brugola testa svasata mm 30x8

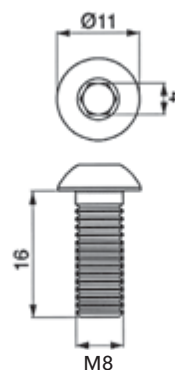

**Art.10.3089**

Vite brugola per taschetta mm 16x8

MINILOCK CON BATTUTA					
	H	Tipo	kg		
Art.71.2002	350	DX	1,025		
Art.71.2004	350	SX	1,025		
Art.71.2006	400	DX	1,075		
Art.71.2008	400	SX	1,075		
Art.71.2010	500	DX	1,120		
Art.71.2012	500	SX	1,120		
Art.71.2014	600	DX	1,275		
Art.71.2016	600	SX	1,275		
Art.71.2018	800	DX	1,440		
Art.71.2020	800	SX	1,440		
Art.71.2022	1000	DX	2,500		
Art.71.2024	1000	SX	2,500		
Art.71.2019 Leva bassa			800	DX	2,580
Art.71.2021 Leva bassa			800	SX	2,580

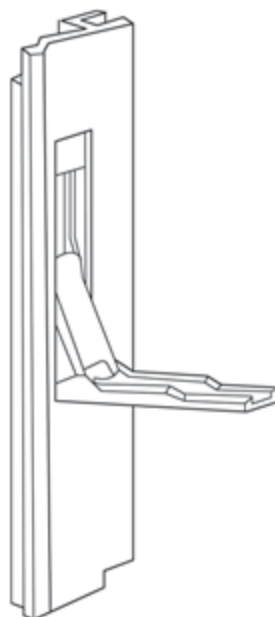

MINILOCK SENZA BATTUTA					
	H	Tipo	kg		
Art.71.2102	350	DX	0,980		
Art.71.2104	350	SX	0,980		
Art.71.2106	400	DX	1,040		
Art.71.2108	400	SX	1,040		
Art.71.2110	500	DX	1,135		
Art.71.2112	500	SX	1,135		
Art.71.2114	600	DX	1,230		
Art.71.2116	600	SX	1,230		
Art.71.2118	800	DX	1,395		
Art.71.2120	800	SX	1,395		
Art.71.2122	1000	DX	2,400		
Art.71.2124	1000	SX	2,400		
Art.71.2119 Leva bassa			800	DX	2,480
Art.71.2121 Leva bassa			800	SX	2,480

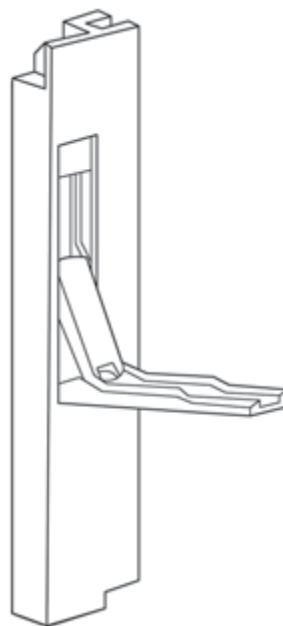

MINILOCK PER SPONDE IN ALLUMINIO



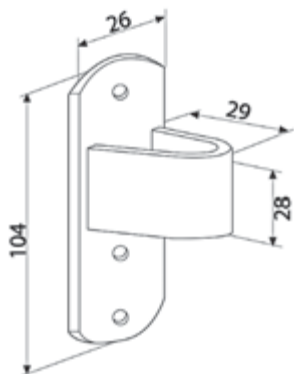

**Art.71.2100**  
 Taschetta diritta da rivettare zincata kg 0,10

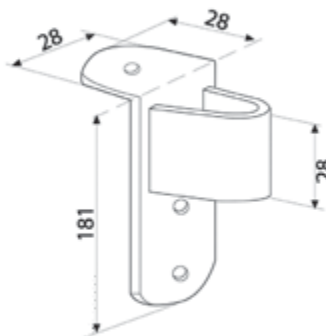

**Art.71.2101**  
 Taschetta piegata da rivettare zincata kg 0,10

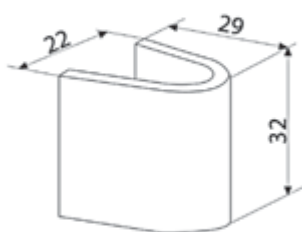

**Art.71.2000**  
 Taschetta da saldare kg 0,09

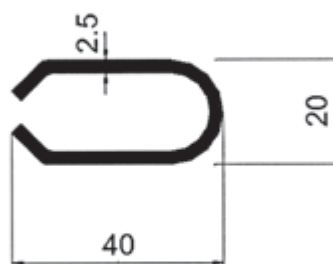

**Art.71.2001**  
 Taschetta a "C" da saldare kg 0,09

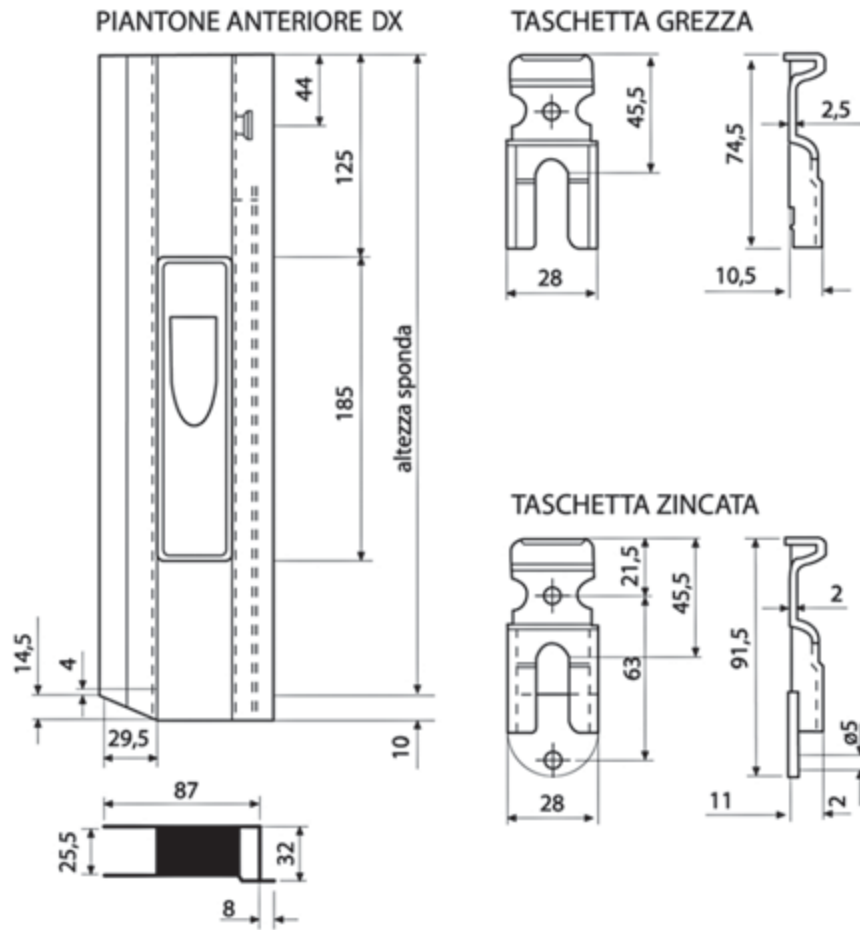

	Descrizione	kg
<b>Art.71.4504</b>	Chiusura ant. DX H 400	0,800
<b>Art.71.4505</b>	Chiusura ant. SX H 400	0,800
<b>Art.71.4507</b>	Taschetta da saldare grezza	0,050
<b>Art.71.4508</b>	Taschetta da rivettare zincata	0,050

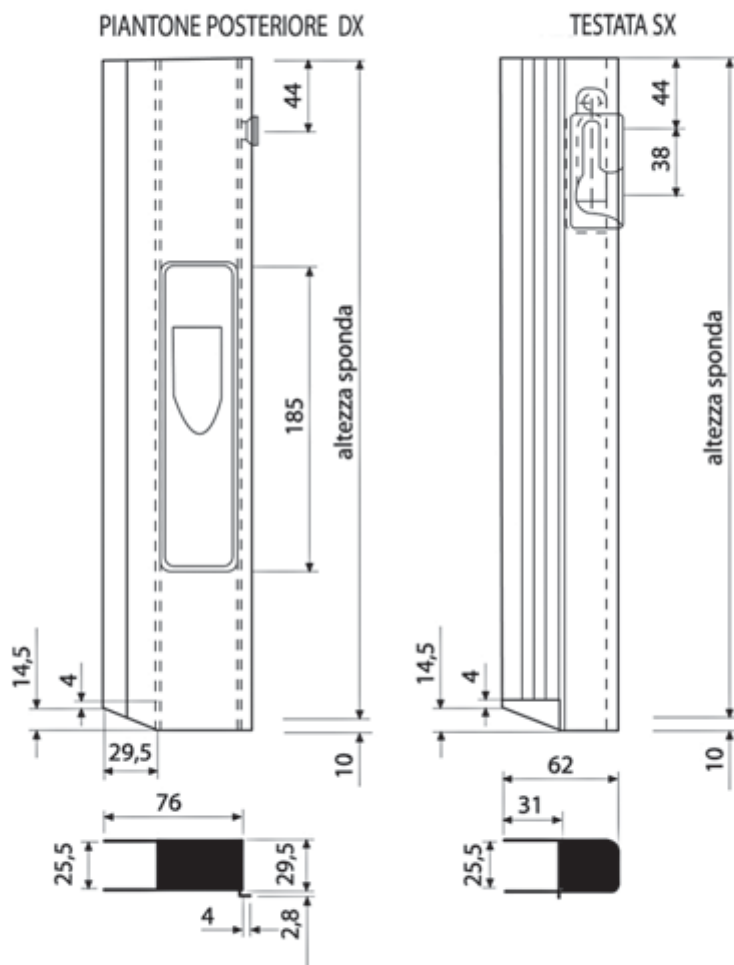

	Descrizione	kg
<b>Art.71.4520</b>	Chiusura post. DX H 400	0,600
<b>Art.71.4522</b>	Chiusura post. SX H 400	0,600
<b>Art.71.4524</b>	Testata post. DX H 400	0,200
<b>Art.71.4526</b>	Testata post. SX H 400	0,200

SERIE BB2 ANTERIORE CON BATTUTA PERNO ORIZZONTALE

SX

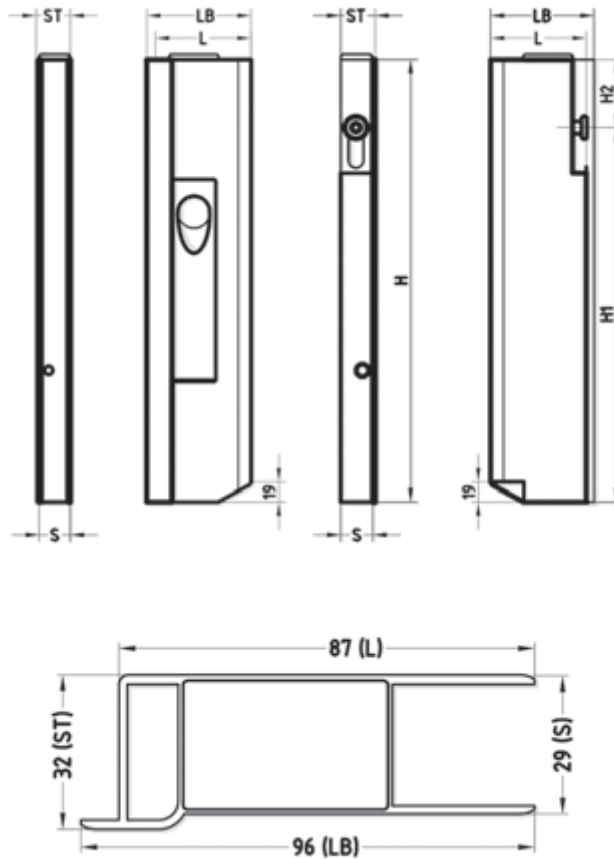

	Descrizione	H	H1	H2	kg
<b>Art.71.4000</b>	DX-maniglia verticale doppia camera p.o. c.b.	310	250	60	0,770
<b>Art.71.4002</b>	SX-maniglia verticale doppia camera p.o. c.b.	310	250	60	0,770
<b>Art.71.4004</b>	DX-maniglia verticale doppia camera p.o. c.b.	360	300	60	0,845
<b>Art.71.4006</b>	SX-maniglia verticale doppia camera p.o. c.b.	360	300	60	0,845
<b>Art.71.4008</b>	DX-maniglia verticale doppia camera p.o. c.b.	410	350	60	0,975
<b>Art.71.4010</b>	SX-maniglia verticale doppia camera p.o. c.b.	410	350	60	0,975
<b>Art.71.4012</b>	DX-maniglia verticale doppia camera p.o. c.b.	510	450	60	1,020
<b>Art.71.4014</b>	SX-maniglia verticale doppia camera p.o. c.b.	510	450	60	1,020
<b>Art.71.4016</b>	DX-maniglia verticale doppia camera p.o. c.b.	610	550	60	1,150
<b>Art.71.4018</b>	SX-maniglia verticale doppia camera p.o. c.b.	610	550	60	1,150

SERIE BB2 POSTERIORE CON BATTUTA PERNO ORIZZONTALE

SX

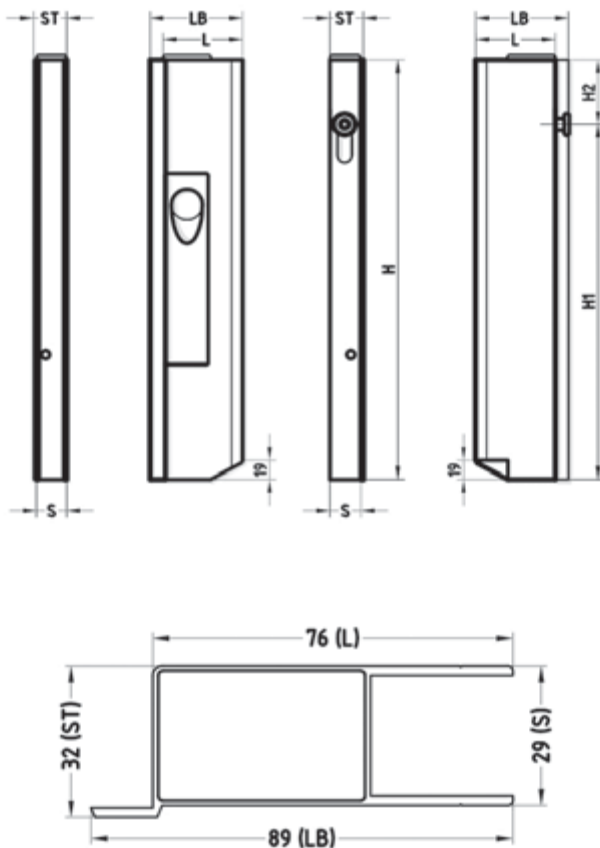

	Descrizione	H	H1	H2	kg
<b>Art.71.4020</b>	DX-maniglia verticale p.o. c.b.	310	250	60	0,760
<b>Art.71.4022</b>	SX-maniglia verticale p.o. c.b.	310	250	60	0,760
<b>Art.71.4024</b>	DX-maniglia verticale p.o. c.b.	360	300	60	0,815
<b>Art.71.4026</b>	SX-maniglia verticale p.o. c.b.	360	300	60	0,815
<b>Art.71.4028</b>	DX-maniglia verticale p.o. c.b.	410	350	60	0,855
<b>Art.71.4030</b>	SX-maniglia verticale p.o. c.b.	410	350	60	0,855
<b>Art.71.4032</b>	DX-maniglia verticale p.o. c.b.	510	450	60	0,960
<b>Art.71.4034</b>	SX-maniglia verticale p.o. c.b.	510	450	60	0,960
<b>Art.71.4036</b>	DX-maniglia verticale p.o. c.b.	610	550	60	1,060
<b>Art.71.4038</b>	SX-maniglia verticale p.o. c.b.	610	550	60	1,060

SERIE BB2 ANTERIORE SENZA BATTUTA PERNO ORIZZONTALE

SX

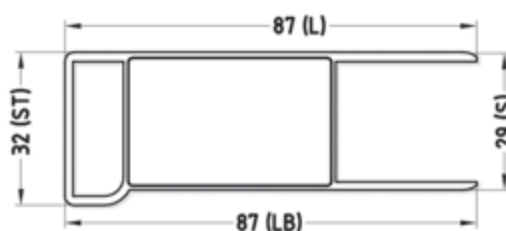
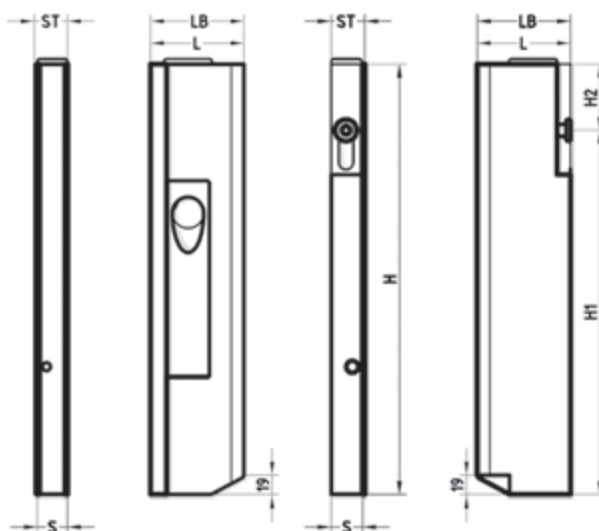

	Descrizione	H	H1	H2	kg
<b>Art.71.4200</b>	DX-maniglia verticale doppia camera p.o. s.b.	310	250	60	0,780
<b>Art.71.4202</b>	SX-maniglia verticale doppia camera p.o. s.b.	310	250	60	0,780
<b>Art.71.4204</b>	DX-maniglia verticale doppia camera p.o. s.b.	360	300	60	0,850
<b>Art.71.4206</b>	SX-maniglia verticale doppia camera p.o. s.b.	360	300	60	0,850
<b>Art.71.4208</b>	DX-maniglia verticale doppia camera p.o. s.b.	410	350	60	0,915
<b>Art.71.4210</b>	SX-maniglia verticale doppia camera p.o. s.b.	410	350	60	0,915
<b>Art.71.4212</b>	DX-maniglia verticale doppia camera p.o. s.b.	510	450	60	1,020
<b>Art.71.4214</b>	SX-maniglia verticale doppia camera p.o. s.b.	510	450	60	1,020
<b>Art.71.4216</b>	DX-maniglia verticale doppia camera p.o. s.b.	610	550	60	1,150
<b>Art.71.4218</b>	SX-maniglia verticale doppia camera p.o. s.b.	610	550	60	1,150

SERIE BB2 POSTERIORE SENZA BATTUTA PERNO ORIZZONTALE

SX

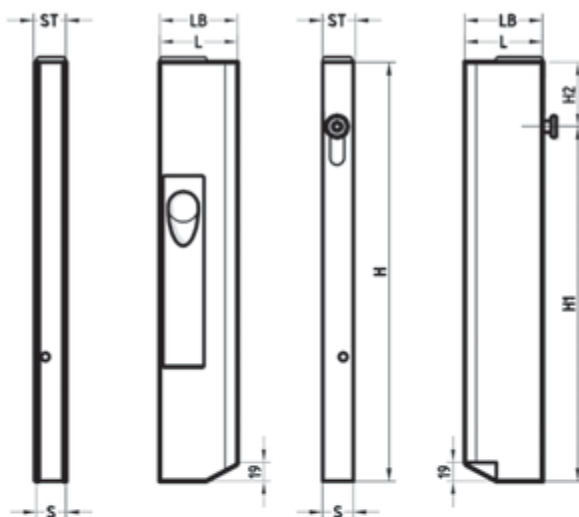

	Descrizione	H	H1	H2	kg
Art.71.4220	DX-maniglia verticale p.o. s.b.	310	250	60	0,740
Art.71.4222	SX-maniglia verticale p.o. s.b.	310	250	60	0,740
Art.71.4224	DX-maniglia verticale p.o. s.b.	360	300	60	0,790
Art.71.4226	SX-maniglia verticale p.o. s.b.	360	300	60	0,790
Art.71.4228	DX-maniglia verticale p.o. s.b.	410	350	60	0,840
Art.71.4230	SX-maniglia verticale p.o. s.b.	410	350	60	0,840
Art.71.4232	DX-maniglia verticale p.o. s.b.	510	450	60	0,950
Art.71.4234	SX-maniglia verticale p.o. s.b.	510	450	60	0,950
Art.71.4236	DX-maniglia verticale p.o. s.b.	610	550	60	1,035
Art.71.4238	SX-maniglia verticale p.o. s.b.	610	550	60	1,035

ACCESSORI PER SERIE BB2-BB4: PERNO ORIZZONTALE

DX

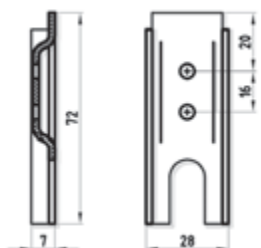

**Art.71.4100**

Riscontro zincato kg 0,05

**Art.71.4100.1**

Riscontro grezzo kg 0,05

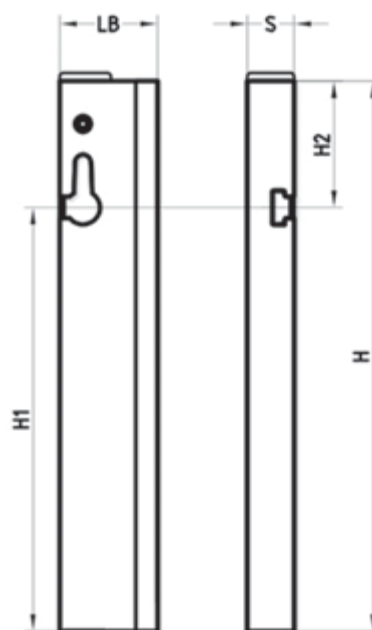
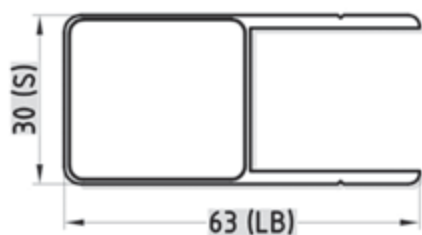

	Descrizione	H	S	H1	H2	kg
<b>Art.71.4040</b>	DX-testatina	310	30	225	85	0,350
<b>Art.71.4042</b>	SX-testatina	310	30	225	85	0,350
<b>Art.71.4044</b>	DX-testatina	360	30	275	85	0,405
<b>Art.71.4046</b>	SX-testatina	360	30	275	85	0,405
<b>Art.71.4048</b>	DX-testatina	410	30	325	85	0,460
<b>Art.71.4050</b>	SX-testatina	410	30	325	85	0,460
<b>Art.71.4052</b>	DX-testatina	510	30	425	85	0,565
<b>Art.71.4054</b>	SX-testatina	510	30	425	85	0,565
<b>Art.71.4056</b>	DX-testatina	610	30	525	85	0,665
<b>Art.71.4058</b>	SX-testatina	610	30	525	85	0,665

TESTATA PER SPONDE IN ALLUMINIO



SERIE BB4 ANTERIORI CON BATTUTA PERNO ORIZZONTALE C/ MANIGLIA VERT. RIBALTABILE

SX

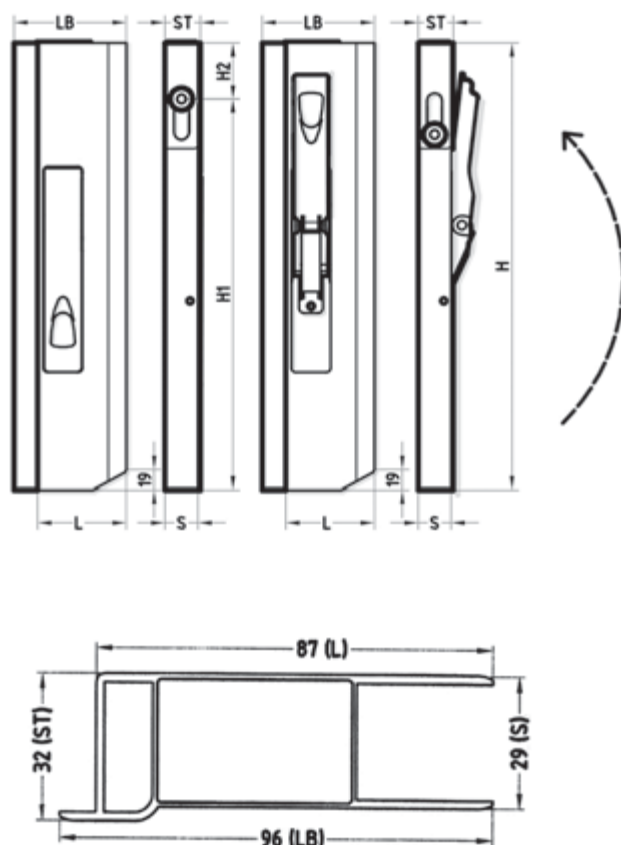

	Descrizione	H	H1	H2	kg
<b>Art.71.4610</b>	DX-maniglia verticale doppia camera p.o. c.b.	310	250	60	0,550
<b>Art.71.4612</b>	SX-maniglia verticale doppia camera p.o. c.b.	310	250	60	0,550
<b>Art.71.4614</b>	DX-maniglia verticale doppia camera p.o. c.b.	360	300	60	0,625
<b>Art.71.4616</b>	SX-maniglia verticale doppia camera p.o. c.b.	360	300	60	0,625
<b>Art.71.4618</b>	DX-maniglia verticale doppia camera p.o. c.b.	410	350	60	0,700
<b>Art.71.4620</b>	SX-maniglia verticale doppia camera p.o. c.b.	410	350	60	0,700
<b>Art.71.4622</b>	DX-maniglia verticale doppia camera p.o. c.b.	510	450	60	0,815
<b>Art.71.4624</b>	SX-maniglia verticale doppia camera p.o. c.b.	510	450	60	0,815
<b>Art.71.4626</b>	DX-maniglia verticale doppia camera p.o. c.b.	610	550	60	0,935
<b>Art.71.4628</b>	SX-maniglia verticale doppia camera p.o. c.b.	610	550	60	0,935

SERIE BB4 POSTERIORI CON BATTUTA PERNO ORIZZONTALE C/ MANIGLIA VERT. RIBALTABILE

SX

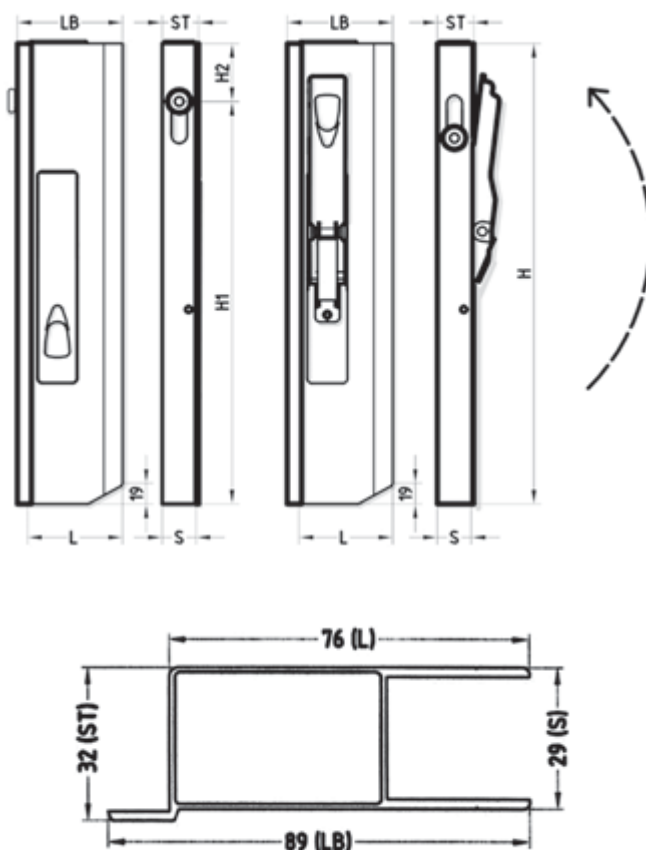

	Descrizione	H	H1	H2	kg
<b>Art.71.4630</b>	DX-maniglia verticale p.o. c.b.	310	250	60	0,520
<b>Art.71.4632</b>	SX-maniglia verticale p.o. c.b.	310	250	60	0,520
<b>Art.71.4634</b>	DX-maniglia verticale p.o. c.b.	360	300	60	0,585
<b>Art.71.4636</b>	SX-maniglia verticale p.o. c.b.	360	300	60	0,585
<b>Art.71.4638</b>	DX-maniglia verticale p.o. c.b.	410	350	60	0,650
<b>Art.71.4640</b>	SX-maniglia verticale p.o. c.b.	410	350	60	0,650
<b>Art.71.4642</b>	DX-maniglia verticale p.o. c.b.	510	450	60	0,750
<b>Art.71.4644</b>	SX-maniglia verticale p.o. c.b.	510	450	60	0,750
<b>Art.71.4646</b>	DX-maniglia verticale p.o. c.b.	610	550	60	0,855
<b>Art.71.4648</b>	SX-maniglia verticale p.o. c.b.	610	550	60	0,855

SERIE BB4 ANTERIORI SENZA BATTUTA PERNO ORIZZONTALE C/ MANIGLIA VERT. RIBALTABILE

SX

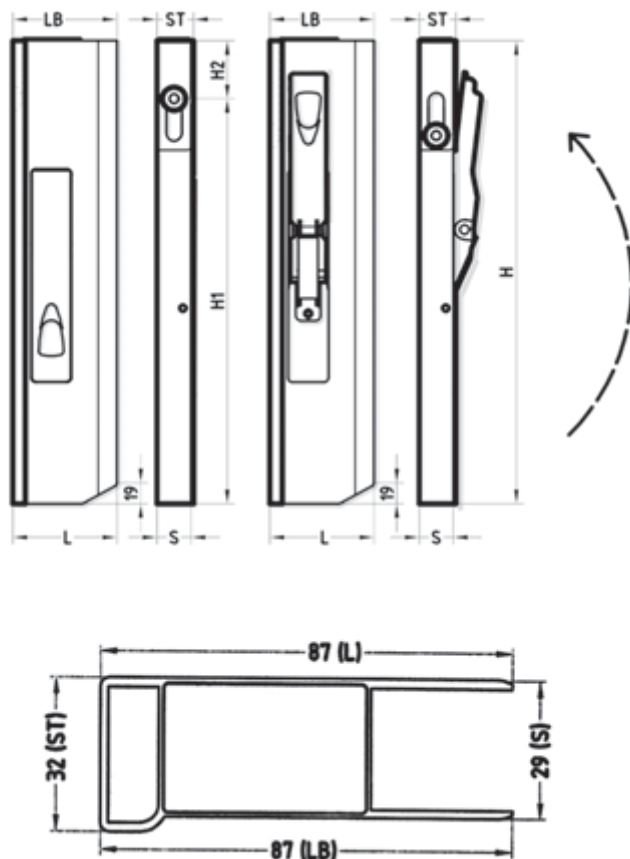

	Descrizione	H	H1	H2	kg
<b>Art.71.4710</b>	DX-maniglia verticale doppia camera p.o. s.b.	310	250	60	0,555
<b>Art.71.4712</b>	SX-maniglia verticale doppia camera p.o. s.b.	310	250	60	0,555
<b>Art.71.4714</b>	DX-maniglia verticale doppia camera p.o. s.b.	360	300	60	0,630
<b>Art.71.4716</b>	SX-maniglia verticale doppia camera p.o. s.b.	360	300	60	0,630
<b>Art.71.4718</b>	DX-maniglia verticale doppia camera p.o. s.b.	410	350	60	0,705
<b>Art.71.4720</b>	SX-maniglia verticale doppia camera p.o. s.b.	410	350	60	0,705
<b>Art.71.4722</b>	DX-maniglia verticale doppia camera p.o. s.b.	510	450	60	0,830
<b>Art.71.4724</b>	SX-maniglia verticale doppia camera p.o. s.b.	510	450	60	0,830
<b>Art.71.4726</b>	DX-maniglia verticale doppia camera p.o. s.b.	610	550	60	0,950
<b>Art.71.4728</b>	SX-maniglia verticale doppia camera p.o. s.b.	610	550	60	0,950

SERIE BB4 POSTERIORE SENZA BATTUTA PERNO ORIZZONTALE C/ MANIGLIA VERT. RIBALTABILE SX

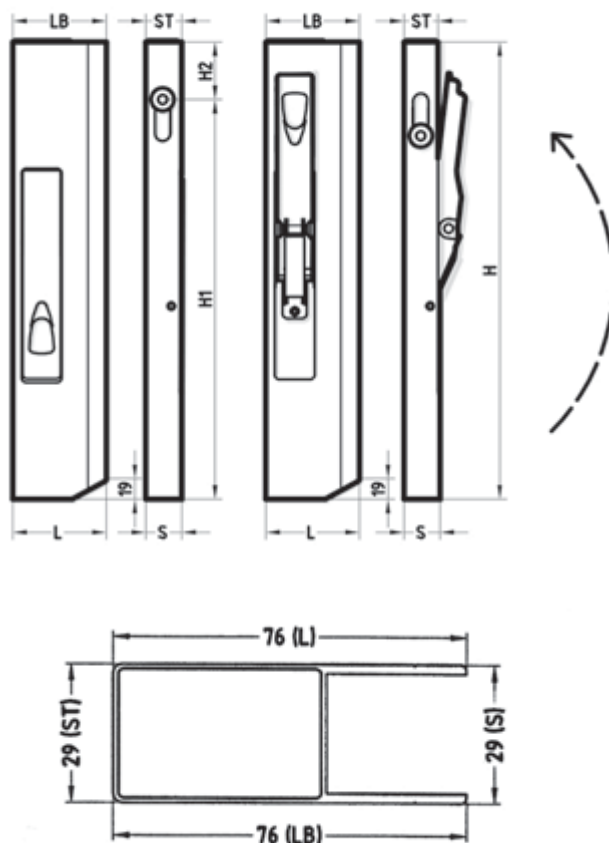

	Descrizione	H	H1	H2	kg
<b>Art.71.4730</b>	DX-maniglia verticale p.o. s.b.	310	250	60	0,500
<b>Art.71.4732</b>	SX-maniglia verticale p.o. s.b.	310	250	60	0,500
<b>Art.71.4734</b>	DX-maniglia verticale p.o. s.b.	360	300	60	0,575
<b>Art.71.4736</b>	SX-maniglia verticale p.o. s.b.	360	300	60	0,575
<b>Art.71.4738</b>	DX-maniglia verticale p.o. s.b.	410	350	60	0,625
<b>Art.71.4740</b>	SX-maniglia verticale p.o. s.b.	410	350	60	0,625
<b>Art.71.4742</b>	DX-maniglia verticale p.o. s.b.	510	450	60	0,720
<b>Art.71.4744</b>	SX-maniglia verticale p.o. s.b.	510	450	60	0,720
<b>Art.71.4746</b>	DX-maniglia verticale p.o. s.b.	610	550	60	0,820
<b>Art.71.4748</b>	SX-maniglia verticale p.o. s.b.	610	550	60	0,820

SERIE BB2 CON BATTUTA PERNO VERTICALE

SX

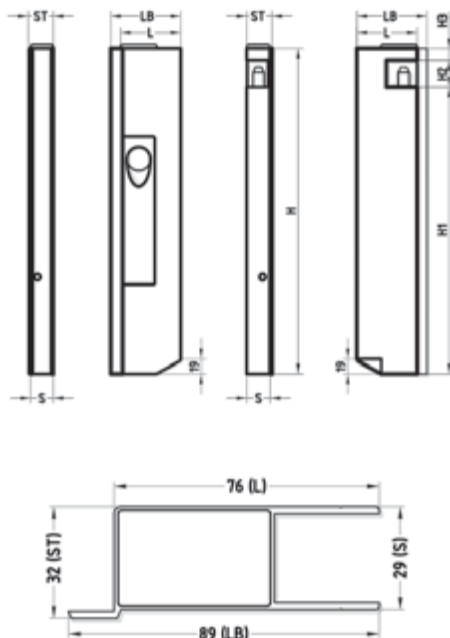

	Descrizione	H	H1	H2	H3	kg
<b>Art.71.4250</b>	DX-maniglia verticale p.v. c.b.	310	261	34	15	0,770
<b>Art.71.4252</b>	SX-maniglia verticale p.v. c.b.	310	261	34	15	0,770
<b>Art.71.4254</b>	DX-maniglia verticale p.v. c.b.	360	311	34	15	0,835
<b>Art.71.4256</b>	SX-maniglia verticale p.v. c.b.	360	311	34	15	0,835
<b>Art.71.4258</b>	DX-maniglia verticale p.v. c.b.	410	361	34	15	0,880
<b>Art.71.4260</b>	SX-maniglia verticale p.v. c.b.	410	361	34	15	0,880
<b>Art.71.4262</b>	DX-maniglia verticale p.v. c.b.	510	461	34	15	0,975
<b>Art.71.4264</b>	SX-maniglia verticale p.v. c.b.	510	461	34	15	0,975
<b>Art.71.4268</b>	DX-maniglia verticale p.v. c.b.	610	561	34	15	1,080
<b>Art.71.4270</b>	SX-maniglia verticale p.v. c.b.	610	561	34	15	1,080
<b>Art.71.4272</b>	DX-maniglia verticale p.v. c.b.	810	761	34	15	1,280
<b>Art.71.4274</b>	SX-maniglia verticale p.v. c.b.	810	761	34	15	1,280
<b>Art.71.4276</b>	DX-maniglia verticale p.v. c.b.	1010	961	34	15	1,745
<b>Art.71.4278</b>	SX-maniglia verticale p.v. c.b.	1010	961	34	15	1,745

SERIE BB2 SENZA BATTUTA PERNO VERTICALE

SX

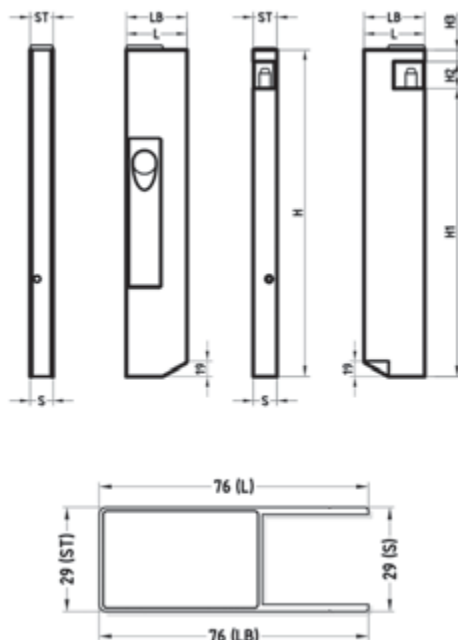

	Descrizione	H	H1	H2	H3	kg
<b>Art.71.4350</b>	DX-maniglia verticale p.v. s.b.	310	261	34	15	0,755
<b>Art.71.4352</b>	SX-maniglia verticale p.v. s.b.	310	261	34	15	0,755
<b>Art.71.4354</b>	DX-maniglia verticale p.v. s.b.	360	311	34	15	0,795
<b>Art.71.4356</b>	SX-maniglia verticale p.v. s.b.	360	311	34	15	0,795
<b>Art.71.4358</b>	DX-maniglia verticale p.v. s.b.	410	361	34	15	0,850
<b>Art.71.4360</b>	SX-maniglia verticale p.v. s.b.	410	361	34	15	0,850
<b>Art.71.4362</b>	DX-maniglia verticale p.v. s.b.	510	461	34	15	0,950
<b>Art.71.4364</b>	SX-maniglia verticale p.v. s.b.	510	461	34	15	0,950
<b>Art.71.4368</b>	DX-maniglia verticale p.v. s.b.	610	561	34	15	1,050
<b>Art.71.4370</b>	SX-maniglia verticale p.v. s.b.	610	561	34	15	1,050
<b>Art.71.4372</b>	DX-maniglia verticale p.v. s.b.	810	761	34	15	1,240
<b>Art.71.4374</b>	SX-maniglia verticale p.v. s.b.	810	761	34	15	1,240
<b>Art.71.4376</b>	DX-maniglia verticale p.v. s.b.	1010	961	34	15	1,675
<b>Art.71.4378</b>	SX-maniglia verticale p.v. s.b.	1010	961	34	15	1,675

TASCA GREZZA SERIE BB2 PERNO VERTICALE

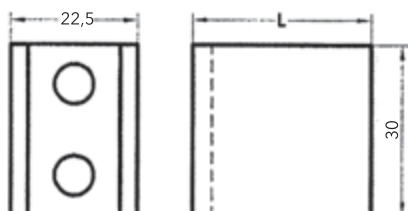

	Tipo	kg
<b>Art.71.4102</b>	Tasca laterale da saldare L32	0,06
<b>Art.71.4104</b>	Tasca posteriore da saldare L26	0,05

TASCA ZINCATA DA AVVITARE SERIE BB2

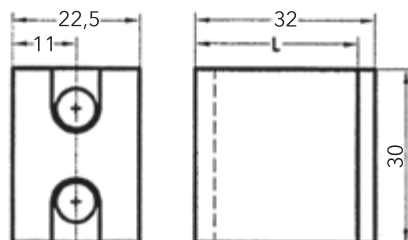

	Tipo	kg
<b>Art.71.4106</b>	Tasca zincata laterale L 32	0,07
<b>Art.71.4108</b>	Tasca zincata posteriore L 25	0,07

TESTATE PER MONTANTI SERIE BB5

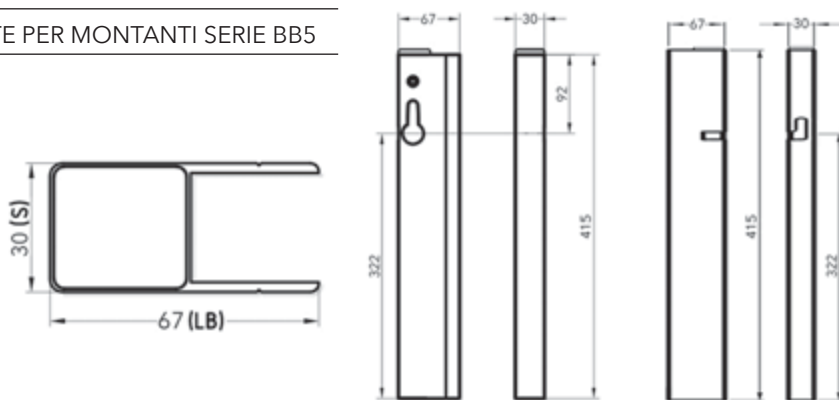

POSTERIORE DESTRA

LATERALE SINISTRA

	Descrizione	kg
<b>Art.14.2530</b>	Laterale DX H 400	0,670
<b>Art.14.2531</b>	Laterale SX H 400	0,670
<b>Art.14.2532</b>	Posteriore DX H 400	0,670
<b>Art.14.2533</b>	Posteriore SX H 400	0,670

MONTANTI SERIE BB5

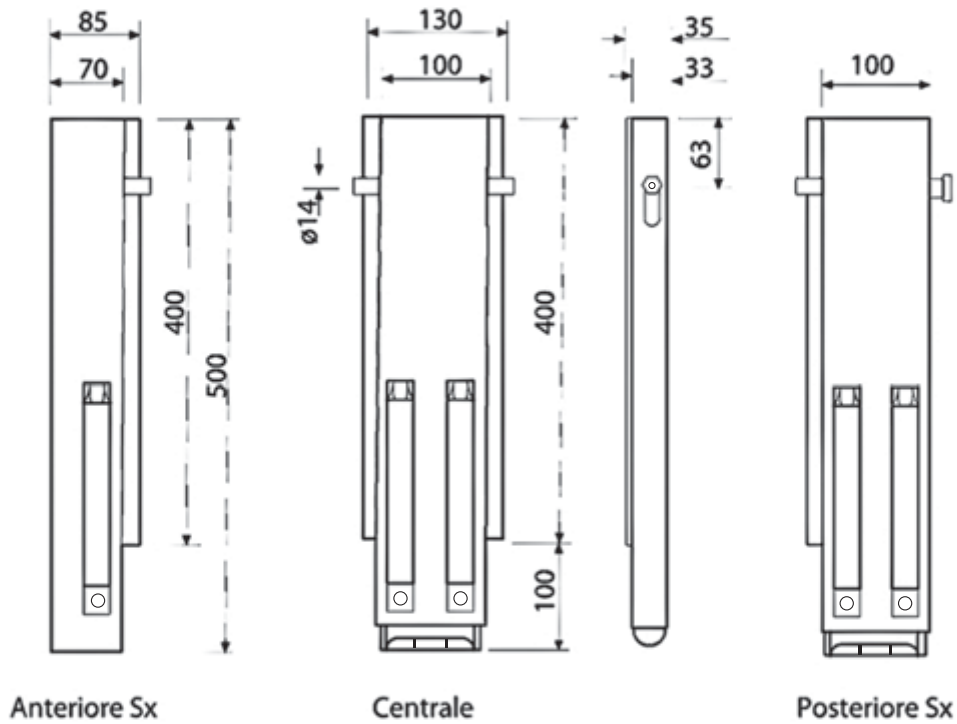

	Descrizione	kg
<b>Art.14.2500</b>	Anteriore DX H 400	3,75
<b>Art.14.2501</b>	Anteriore SX H 400	3,75
<b>Art.14.2504</b>	Centrale H 400	5,56
<b>Art.14.2505</b>	Posteriore DX H 400	5,49
<b>Art.14.2506</b>	Posteriore SX H 400	5,49



MONTANTI CASSONE FISSO S. 33 SERIE BB10

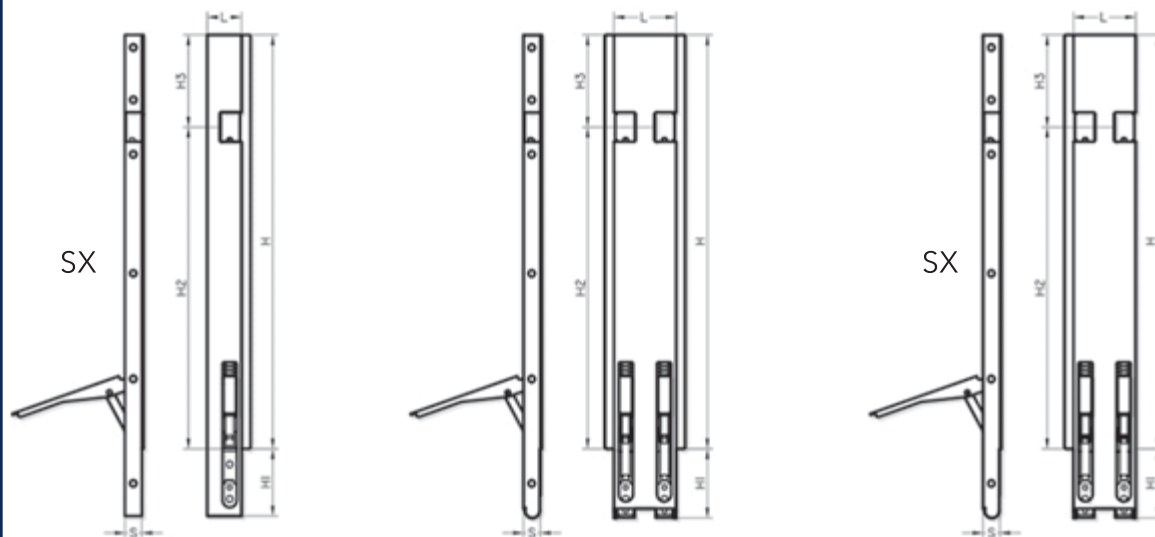

	Descrizione	H	L	H1	H2	H3	kg
<b>Art.14.6010</b>	Anteriore DX da imbullonare	500	66	130	421,5	78,5	4,3
<b>Art.14.6012</b>	Anteriore SX da imbullonare	500	66	130	421,5	78,5	4,3
<b>Art.14.6014</b>	Centrale sganciabile	500	120	127	421,5	78,5	7,6
<b>Art.14.6016</b>	Posteriore DX sganciabile	500	120	127	421,5	78,5	7,4
<b>Art.14.6018</b>	Posteriore SX sganciabile	500	120	127	421,5	78,5	7,4
<b>Art.14.6020</b>	Anteriore DX da imbullonare	600	66	130	471,5	128,5	5,1
<b>Art.14.6022</b>	Anteriore SX da imbullonare	600	66	130	471,5	128,5	5,1
<b>Art.14.6024</b>	Centrale sganciabile	600	120	127	471,5	128,5	8,4
<b>Art.14.6026</b>	Posteriore DX sganciabile	600	120	127	471,5	128,5	8,1
<b>Art.14.6028</b>	Posteriore SX sganciabile	600	120	127	471,5	128,5	8,1
<b>Art.14.6030</b>	Anteriore DX da imbullonare	800	66	130	621,5	178,5	6,7
<b>Art.14.6032</b>	Anteriore SX da imbullonare	800	66	130	621,5	178,5	6,7
<b>Art.14.6034</b>	Centrale sganciabile	800	120	127	621,5	178,5	9,9
<b>Art.14.6036</b>	Posteriore DX sganciabile	800	120	127	621,5	178,5	9,6
<b>Art.14.6038</b>	Posteriore SX sganciabile	800	120	127	621,5	178,5	9,6



**Art.14.410**

Taschetta laterale da rivettare kg 0,27

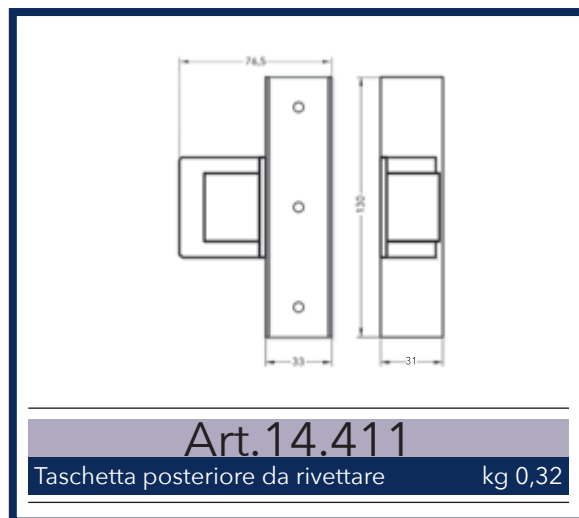

**Art.14.411**

Taschetta posteriore da rivettare kg 0,32

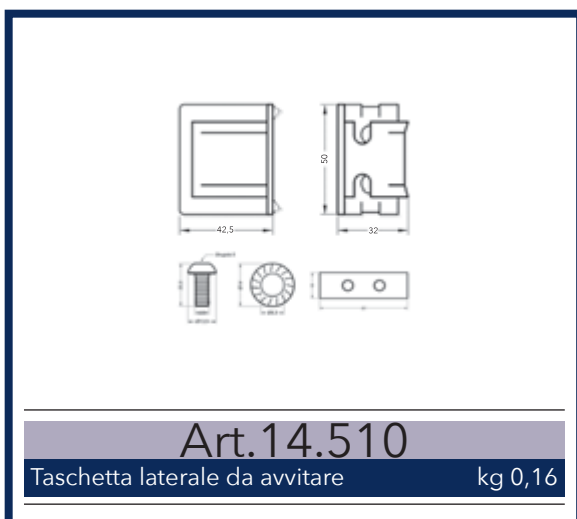

**Art.14.510**

Taschetta laterale da avvitare kg 0,16

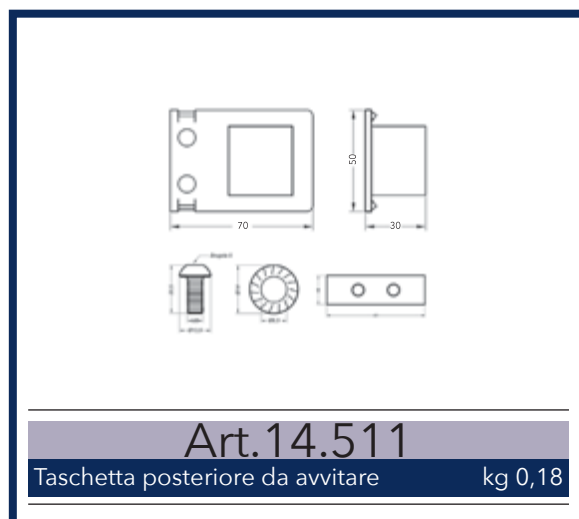

**Art.14.511**

Taschetta posteriore da avvitare kg 0,18

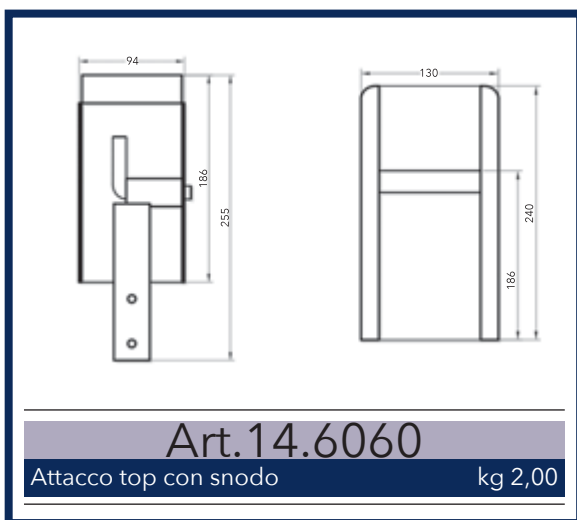

**Art.14.6060**

Attacco top con snodo kg 2,00

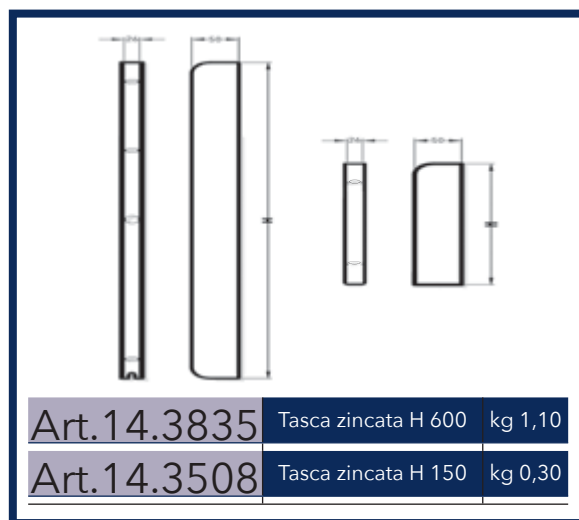

**Art.14.3835** Tasca zincata H 600 kg 1,10

**Art.14.3508** Tasca zincata H 150 kg 0,30

MONTANTI CASSONE FISSO S. 38 SERIE "CP" H 400/500/600

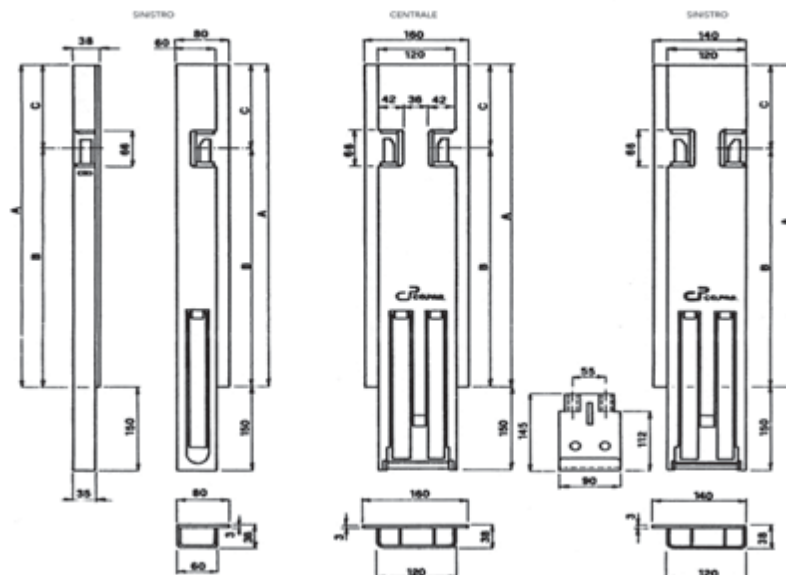

	Descrizione	A	B	C	kg
<b>Art.13.0074D</b>	Anteriore DX da saldare H400	400	345	55	4,0
<b>Art.13.0074S</b>	Anteriore SX da saldare H400	400	345	55	4,0
<b>Art.13.0076</b>	Centrale rovesciabile H400	400	345	55	9,0
<b>Art.13.0079D</b>	Posteriore DX rovesciabile H400	400	345	55	9,0
<b>Art.13.0079S</b>	Posteriore SX rovesciabile H400	400	345	55	9,0
<b>Art.13.0084D</b>	Anteriore DX da saldare H500	500	345	155	4,5
<b>Art.13.0084S</b>	Anteriore SX da saldare H500	500	345	155	4,5
<b>Art.13.0086</b>	Centrale rovesciabile H500	500	345	155	10,0
<b>Art.13.0089D</b>	Posteriore DX rovesciabile H500	500	345	155	10,0
<b>Art.13.0089S</b>	Posteriore SX rovesciabile H500	500	345	155	10,0
<b>Art.13.0094D</b>	Anteriore DX da saldare H600	600	445	155	5,5
<b>Art.13.0094S</b>	Anteriore SX da saldare H600	600	445	155	5,5
<b>Art.13.0096</b>	Centrale rovesciabile H600	600	445	155	11,5
<b>Art.13.0099D</b>	Posteriore DX rovesciabile H600	600	445	155	11,5
<b>Art.13.0099S</b>	Posteriore SX rovesciabile H600	600	445	155	11,5

MONTANTI CASSONE FISSO S. 38 SERIE "CP" H 800/1000

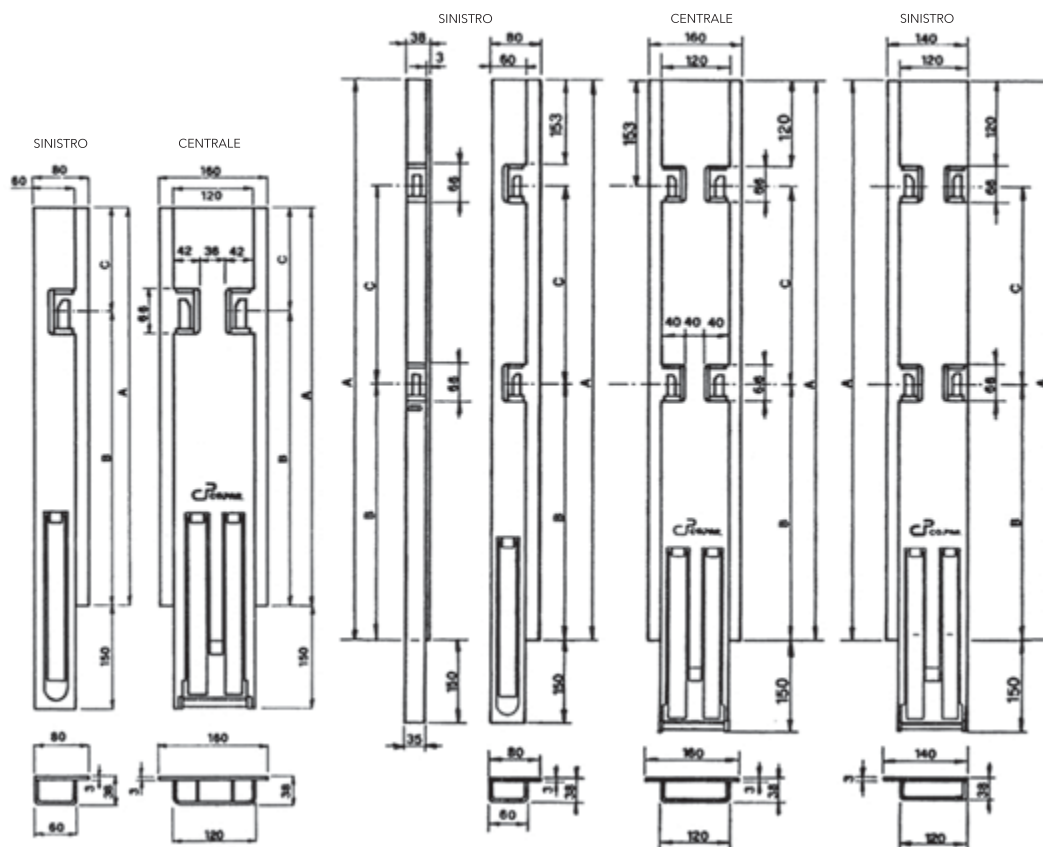

	Descrizione	A	B	C	kg
<b>Art.13.0100D</b>	Anteriore DX da saldare H800	800	582	218	6,0
<b>Art.13.0100S</b>	Anteriore SX da saldare H800	800	582	218	6,0
<b>Art.13.0106</b>	Centrale rovesciabile H800	800	582	218	13,5
<b>Art.13.0109D</b>	Posteriore DX rovesciabile H800	800	582	218	13,5
<b>Art.13.0109S</b>	Posteriore SX rovesciabile H800	800	582	218	13,5
<b>Art.13.0120D</b>	Anteriore DX da saldare H1000	1000	448	399	8,0
<b>Art.13.0120S</b>	Anteriore SX da saldare H1000	1000	448	399	8,0
<b>Art.13.0126</b>	Centrale rovesciabile H1000	1000	448	399	16,0
<b>Art.13.0129D</b>	Posteriore DX rovesciabile H1000	1000	448	399	16,0
<b>Art.13.0129S</b>	Posteriore SX rovesciabile H1000	1000	448	399	16,0

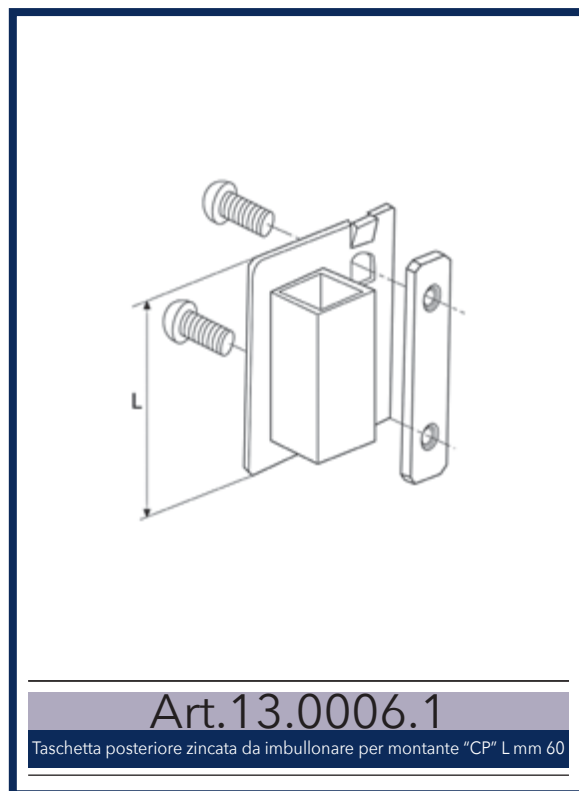
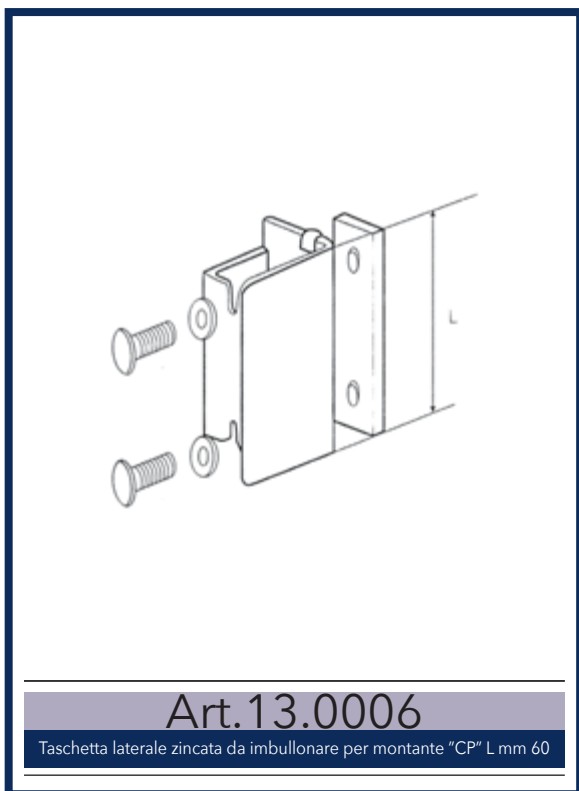
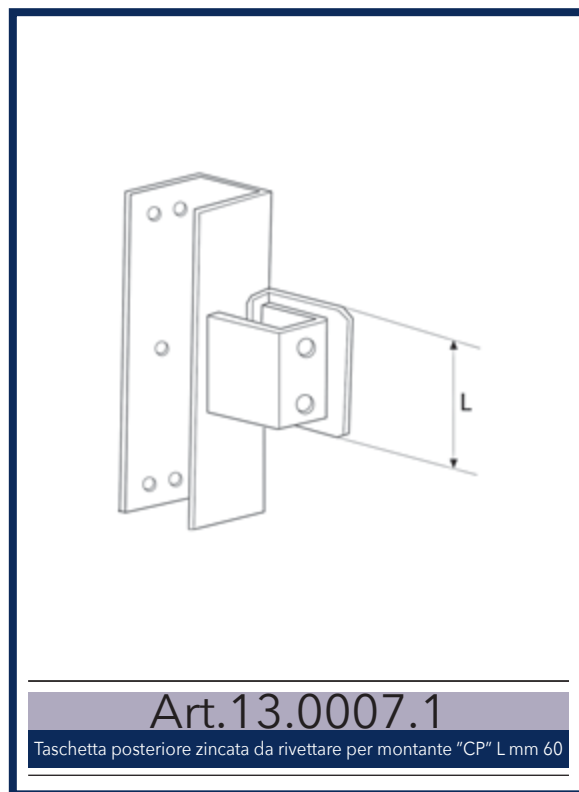
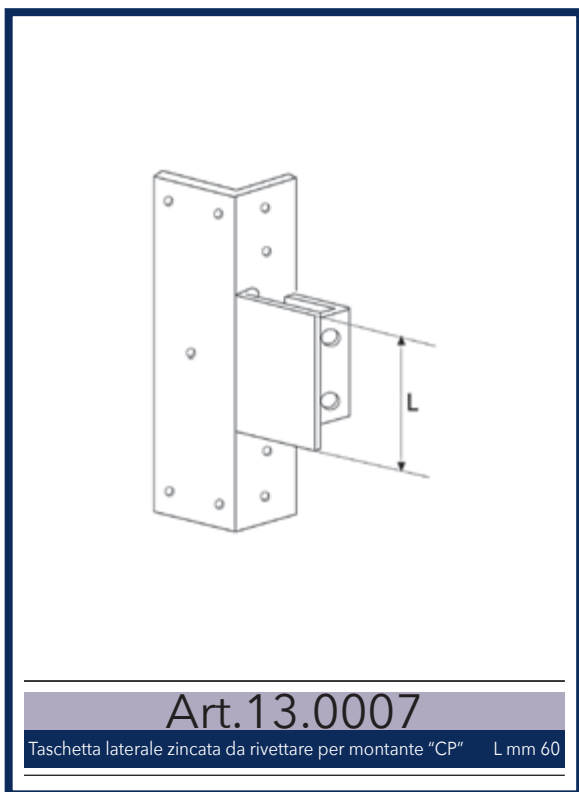

TESTATE ZINCATE PER MONTANTI "CP"

POSTERIORE DESTRA



POSTERIORE SINISTRA



LATERALE DESTRA



LATERALE SINISTRA



H	Laterale Destra	Laterale Sinistra	Posteriore Destra	Posteriore Sinistra	kg
400	Art.14.426	Art.14.427	Art.14.428	Art.14.429	0,90
500	Art.14.430	Art.14.431	Art.14.432	Art.14.433	1,00
600	Art.14.435	Art.14.436	Art.14.437	Art.14.438	1,10
800	Art.14.465	Art.14.466	Art.14.467	Art.14.468	1,40
1000	Art.14.469	Art.14.470	Art.14.471	Art.14.472	1,80

MONTANTI KINNEGRIP K4 H.600

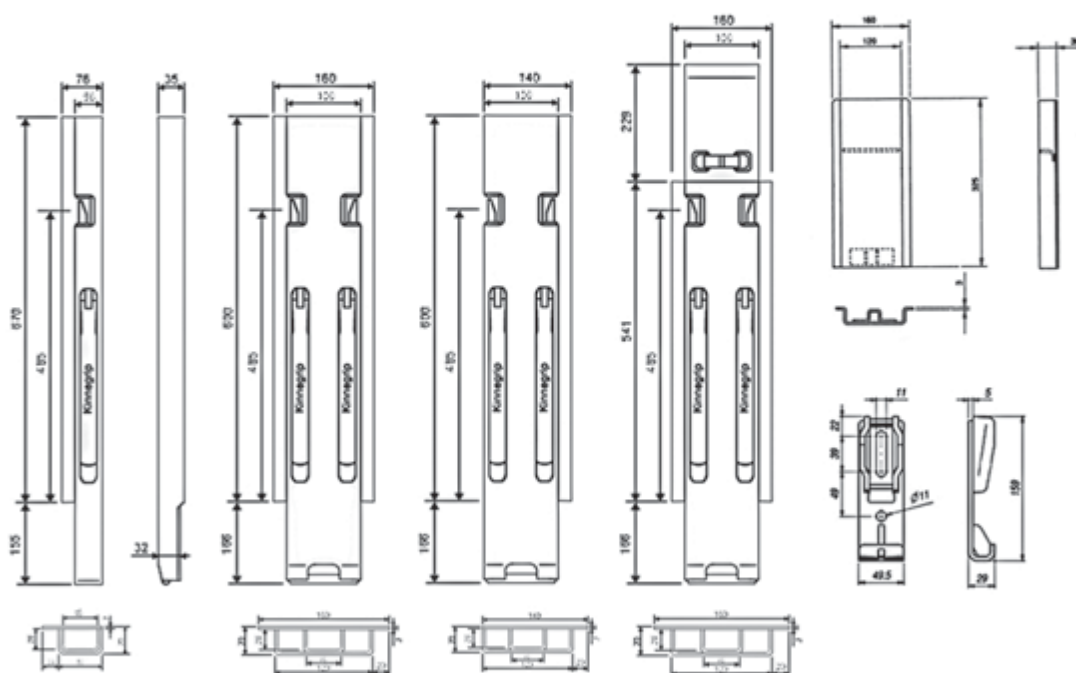

	Descrizione	kg
<b>Art.14.1200D</b>	Anteriore DX da saldare H 600 K4	5,8
<b>Art.14.1200S</b>	Anteriore SX da saldare H 600 K4	5,8
<b>Art.14.1202</b>	Centrale rovesciabile H 600 K4	12,0
<b>Art.14.1204D</b>	Posteriore DX rovesciabile H 600 K4	11,6
<b>Art.14.1204S</b>	Posteriore SX rovesciabile H 600 K4	11,6
<b>Art.14.1208</b>	kinnetop rovesciabile H 600 K4	13,4
<b>Art.14.1220</b>	Supporto a saldare K4	0,56
<b>Art.14.1230</b>	Prolunga kinnetop K4	1,81

MONTANTI KINNEGRIP K4 H.800

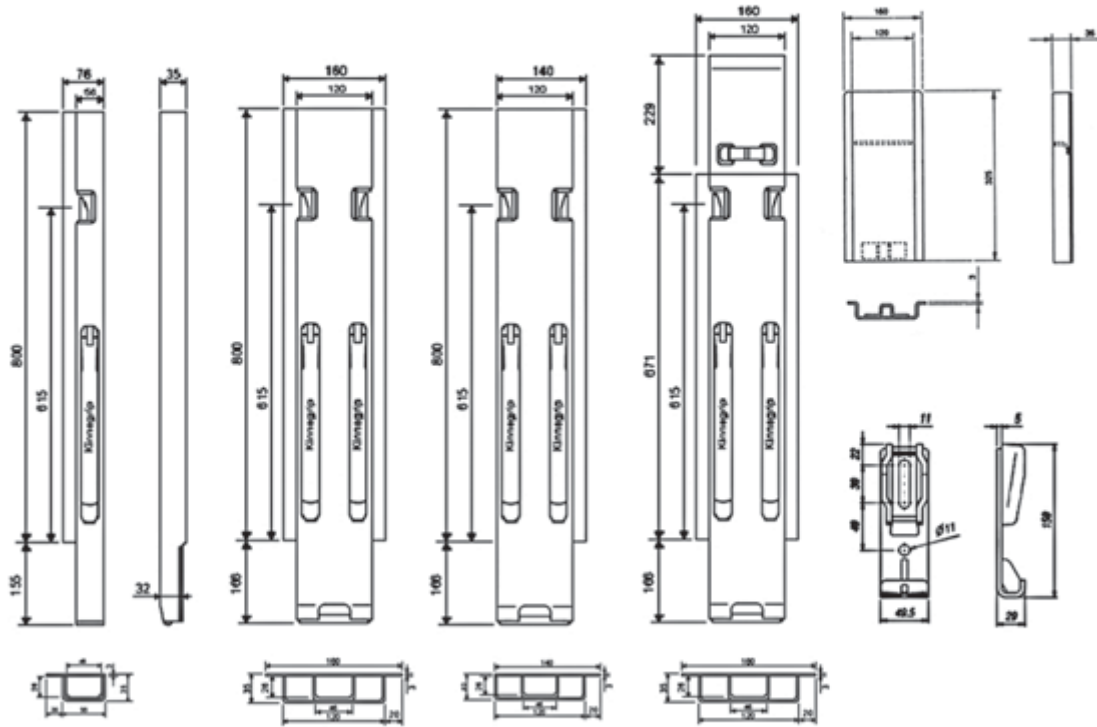

	Descrizione	kg
Art.14.1210D	Anteriore DX da saldare H 800 K4	6,5
Art.14.1210S	Anteriore SX da saldare H 800 K4	6,5
Art.14.1212	Centrale rovesciabile H 800 K4	13,8
Art.14.1214D	Posteriore DX rovesciabile H 800 K4	13,2
Art.14.1214S	Posteriore SX rovesciabile H 800 K4	13,2
Art.14.1218	kinnetop rovesciabile H 800 K4	15,0
Art.14.1220	Supporto a saldare K4	0,56
Art.14.1230	Prolunga kinnetop K4	1,81



MONTANTI KINNEGRIP K20 H.400

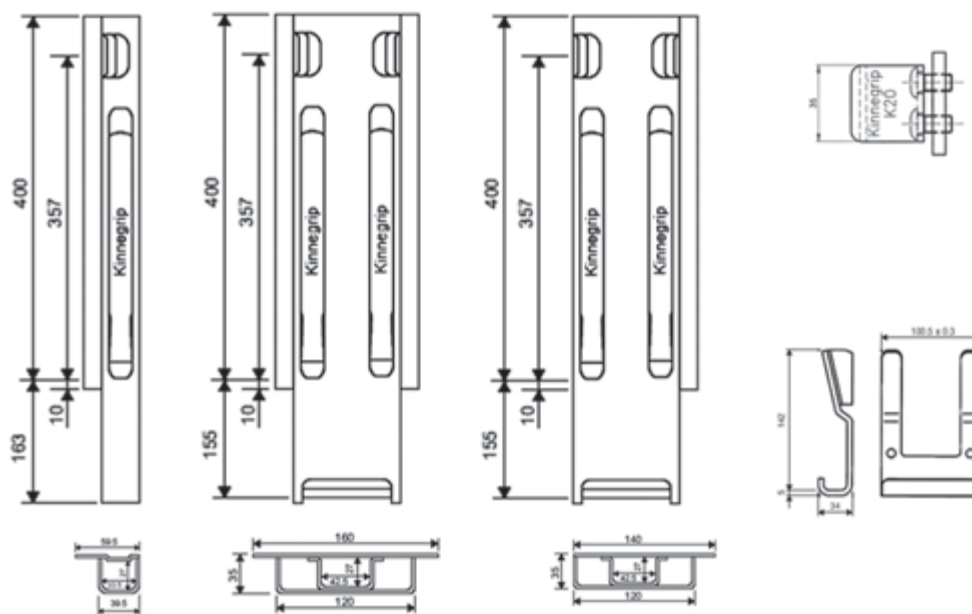

	Descrizione	kg
<b>Art.14.1240D</b>	Anteriore DX da saldare H 400 K20	2,5
<b>Art.14.1240S</b>	Anteriore SX da saldare H 400 K20	2,5
<b>Art.14.1242</b>	Centrale rovesciabile H 400 K20	7,9
<b>Art.14.1244D</b>	Posteriore DX rovesciabile H 400 K20	7,7
<b>Art.14.1244S</b>	Posteriore SX rovesciabile H 400 K20	7,7
<b>Art.14.1290</b>	Supporto montante K20 a saldare	0,56
<b>Art.14.1292</b>	Taschetta zincata K20 da avvitare	0,15

MONTANTI KINNEGRIP K20 H.500

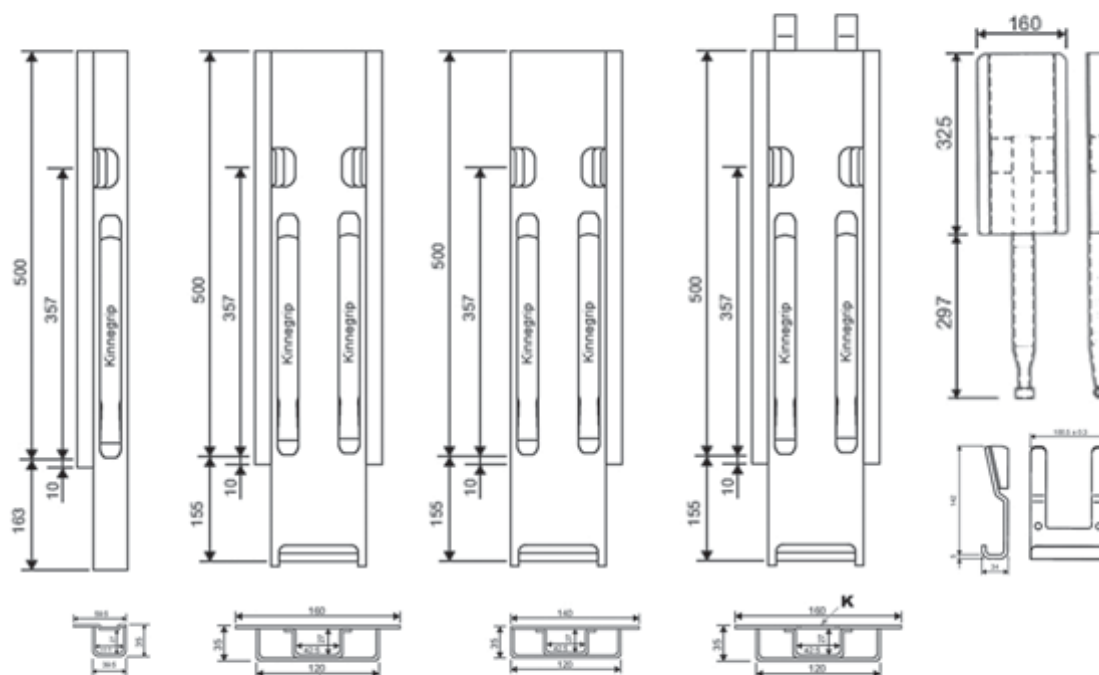

	Descrizione	kg
<b>Art.14.1250D</b>	Anteriore DX da saldare H 500 K20	2,8
<b>Art.14.1250S</b>	Anteriore SX da saldare H 500 K20	2,8
<b>Art.14.1252</b>	Centrale rovesciabile H 500 K20	8,9
<b>Art.14.1254D</b>	Posteriore DX rovesciabile H 500 K20	8,7
<b>Art.14.1254S</b>	Posteriore SX rovesciabile H 500 K20	8,7
<b>Art.14.1258</b>	kinnetop rovesciabile H 500 K20	8,6
<b>Art.14.1290</b>	Supporto montante K20 a saldare	0,56
<b>Art.14.1294</b>	Prolunga con snodo K20	3,60

MONTANTI KINNEGRIP K20 H.600

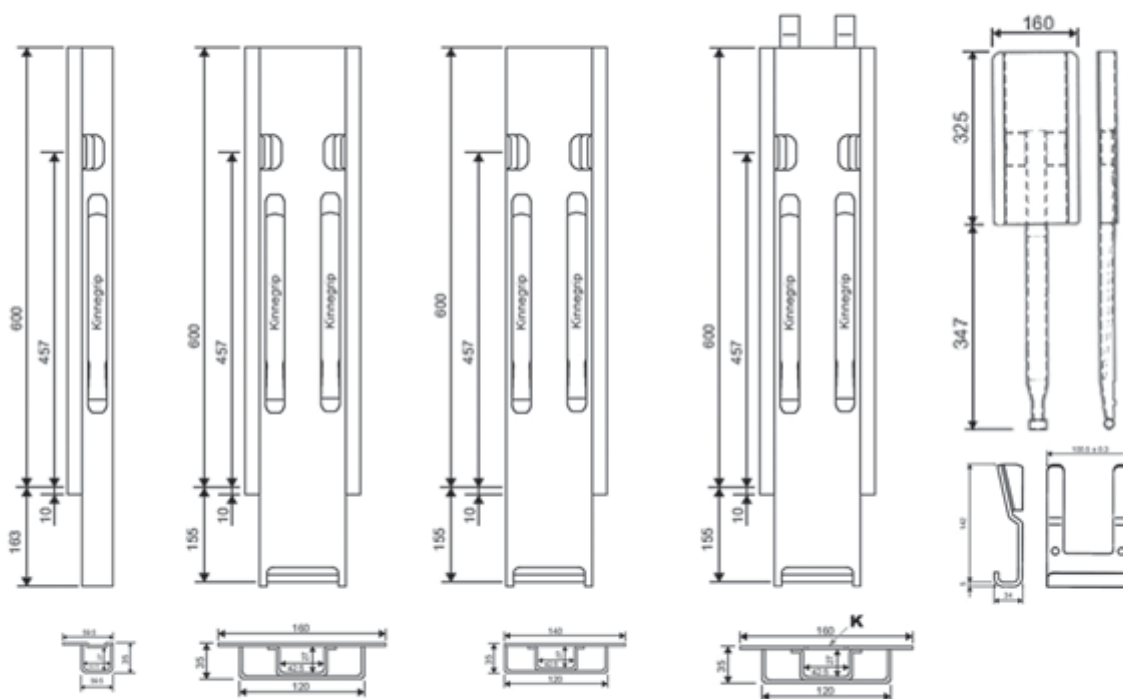

	Descrizione	kg
<b>Art.14.1260D</b>	Anteriore DX da saldare H 600 K20	3,1
<b>Art.14.1260S</b>	Anteriore SX da saldare H 600 K20	3,1
<b>Art.14.1262</b>	Centrale rovesciabile H 600 K20	9,8
<b>Art.14.1264D</b>	Posteriore DX rovesciabile H 600 K20	9,6
<b>Art.14.1264S</b>	Posteriore SX rovesciabile H 600 K20	9,6
<b>Art.14.1268</b>	kinnetop rovesciabile H 600 K20	9,5
<b>Art.14.1290</b>	Supporto montante K20 a saldare	0,56
<b>Art.14.1295</b>	Prolunga con snodo K20	3,65

MONTANTI KINNEGRIP K20 H.800

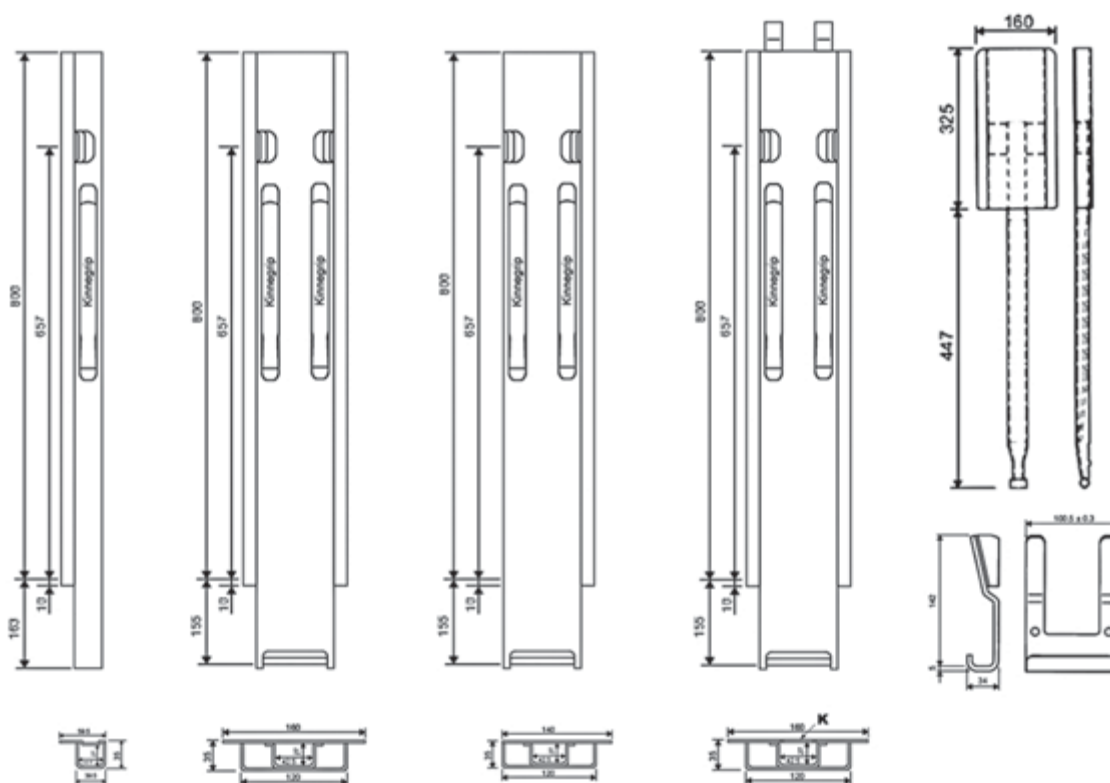

	Descrizione	kg
<b>Art.14.1280D</b>	Anteriore DX da saldare H 800 K20	4,0
<b>Art.14.1280S</b>	Anteriore SX da saldare H 800 K20	4,0
<b>Art.14.1282</b>	Centrale rovesciabile H 800 K20	12,0
<b>Art.14.1284D</b>	Posteriore DX rovesciabile H 800 K20	11,6
<b>Art.14.1284S</b>	Posteriore SX rovesciabile H 800 K20	11,6
<b>Art.14.1288</b>	kinnetop rovesciabile H 800 K20	11,8
<b>Art.14.1290</b>	Supporto montante K20 a saldare	0,56
<b>Art.14.1296</b>	Prolunga con snodo K20	4,00

MONTANTI BB7 H.2800 CHIUSURA ORIZZONTALE

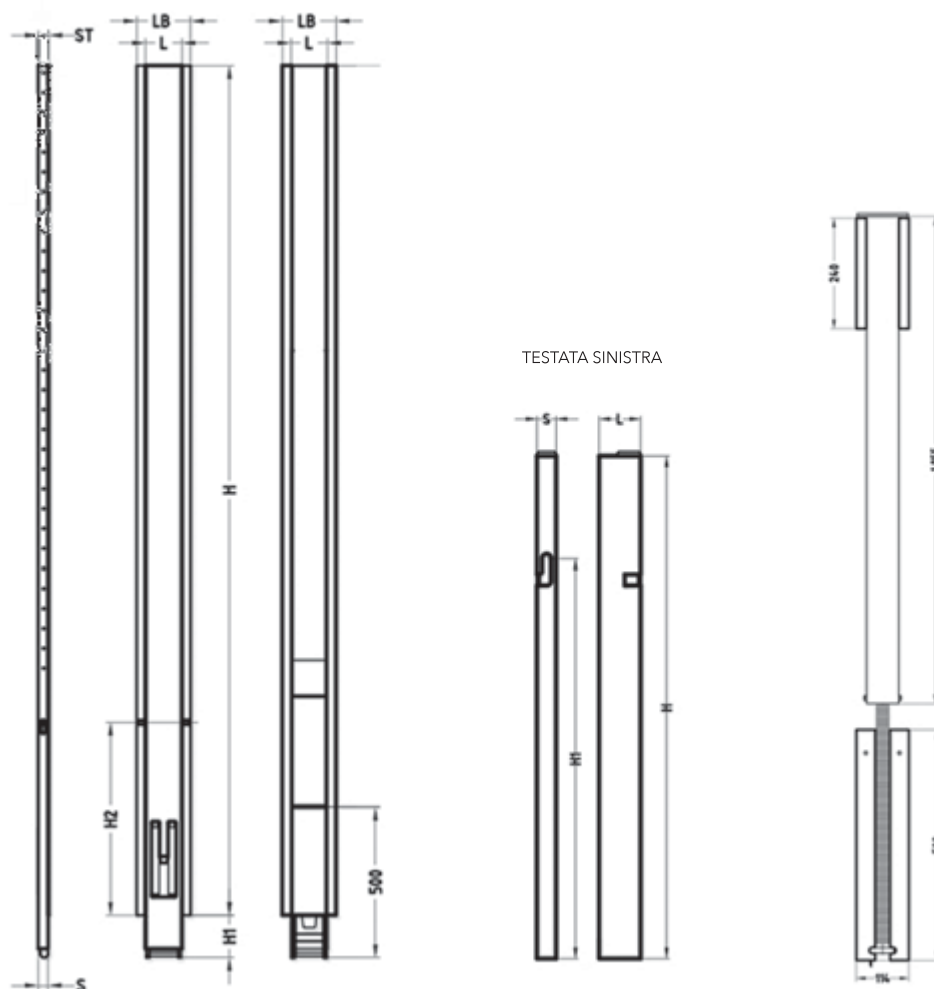

	Descrizione	H	L	S	H1	H2	kg
<b>Art.14.2601</b>	Centrale sganciabile chiusura H 600	2800	120	32,5	140	484	22,8
<b>Art.14.2602</b>	Centrale sganciabile chiusura H 800	2800	120	32,5	140	634	23,2
<b>Art.14.964</b>	Testata alluminio H 600 DX	613	67	31	497		1,0
<b>Art.14.965</b>	Testata alluminio H 600 SX	613	67	31	497		1,0
<b>Art.14.968</b>	Testata alluminio H 800 DX	813	67	31	647		1,3
<b>Art.14.969</b>	Testata alluminio H 800 SX	813	67	31	647		1,3
<b>Art.14.3026</b>	Kit molla per montante						6,6

MONTANTI BB7 H.2800 CURTAINSIDER E MONOLEVA

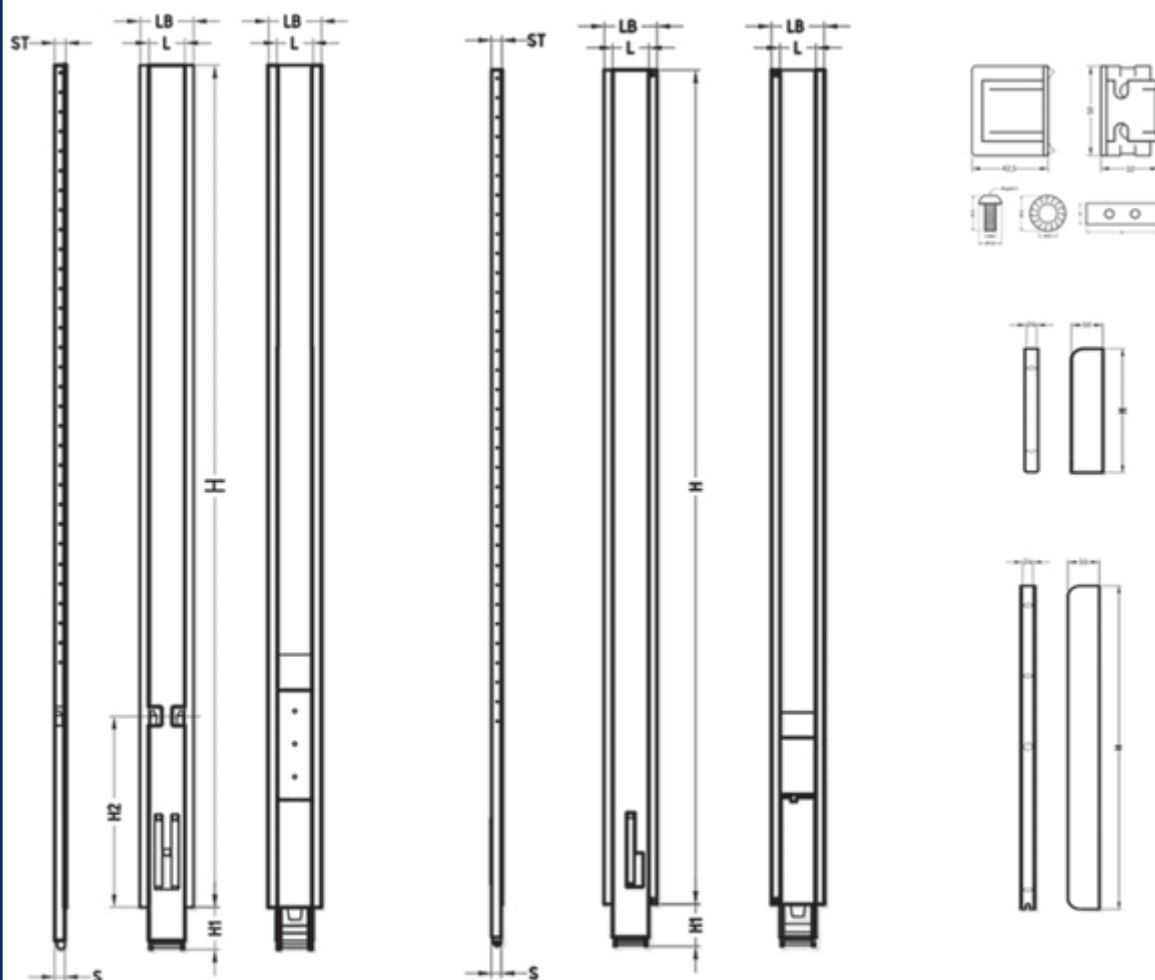

	Descrizione	H	L	S	H1	H2	kg
<b>Art.14.2614</b>	Centrale sganciabile chiusura H 600	2800	120	32,5	140	484	22,8
<b>Art.14.2612</b>	Centrale sganciabile chiusura H 800	2800	120	32,5	140	634	23,2
<b>Art.14.2620</b>	Centrale sganciabile chiusura H 600 inox	3000	120	32,5	120	555	21
<b>Art.14.510</b>	Taschetta zincata avvitare						1,0
<b>Art.14.2604.1</b>	Centrale sganciabile monoleva	2800	120	32,5	140		21,5
<b>Art.14.2630</b>	Centrale sganciabile monoleva inox fior.	3000	120	32,5	120		15
<b>Art.14.3508</b>	Tasca zincata portaperlina	150	50	26			0,3
<b>Art.14.3835</b>	Tasca zincata portaperlina	600	50	26			1,1

MONTANTI PER RIBALTABILI INNESTO A CUNEO LEGGERO SP. 36

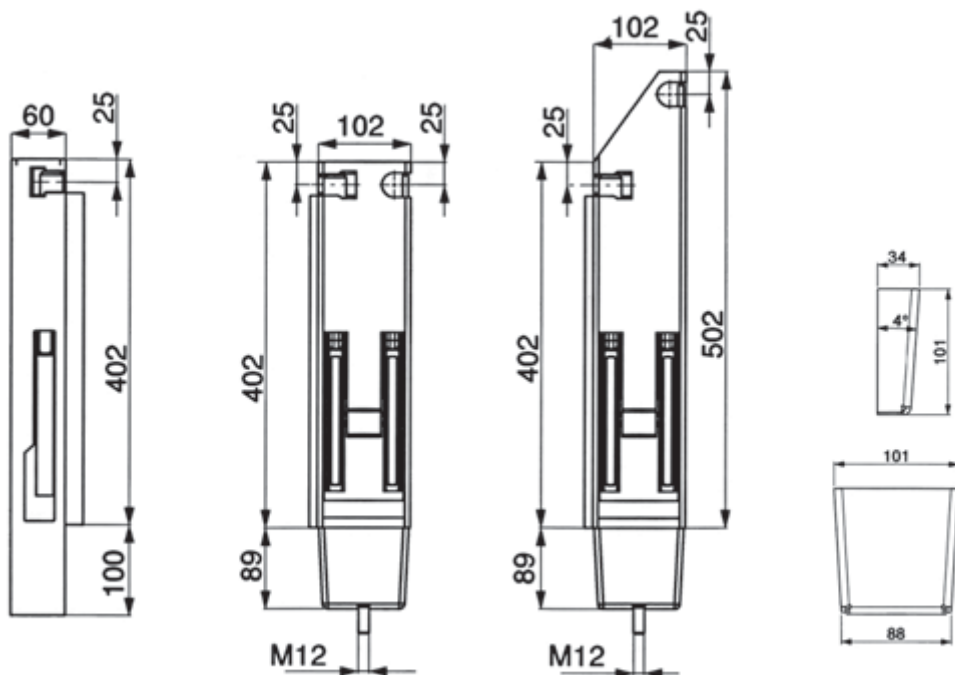

	Descrizione	kg
<b>Art.13.1900D</b>	Montante anteriore destro H 400 L 60	3,50
<b>Art.13.1900S</b>	Montante anteriore sinistro H 400 L 60	3,50
<b>Art.13.1901D</b>	Montante posteriore destro H 400 L 102	7,50
<b>Art.13.1901S</b>	Montante posteriore sinistro H 400 L 102	7,50
<b>Art.13.1907D</b>	Montante posteriore destro H 400/500 L 102	8,50
<b>Art.13.1907S</b>	Montante posteriore sinistro H 400/500 L 102	8,50
<b>Art.13.1904</b>	Sede innesto leggero	0,50

MONTANTI PER RIBALTABILI INNESTO A CUNEO LEGGERO SP. 38

ANTERIORE SX



POSTERIORE SX

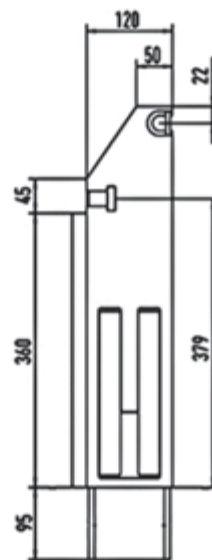

	Descrizione	kg
<b>Art.13.1910D</b>	Montante anteriore destro H 400 L 80	3,50
<b>Art.13.1910S</b>	Montante anteriore sinistro H 400 L 80	3,50
<b>Art.13.1916D</b>	Montante posteriore destro H 400 L 120	7,50
<b>Art.13.1916S</b>	Montante posteriore sinistro H 400 L 120	7,50
<b>Art.13.1918D</b>	Montante posteriore destro H 400/500 L 120	8,50
<b>Art.13.1918S</b>	Montante posteriore sinistro H 400/500 L 120	8,50



MONTANTI CASSONE RIBALTABILE ROVESCIBILI SP. 38

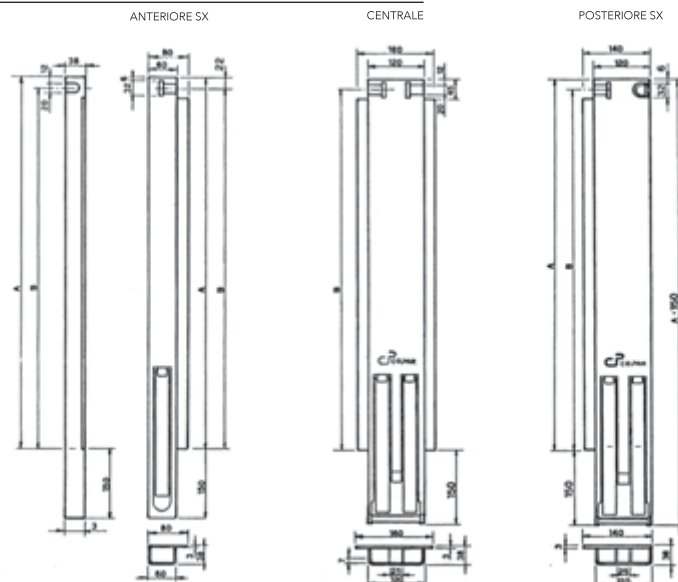

	Descrizione	A	B	kg
<b>Art.13.0802D</b>	Anteriore DX da saldare H400	400	378	4,0
<b>Art.13.0802S</b>	Anteriore SX da saldare H400	400	378	4,0
<b>Art.13.0806</b>	Centrale rovesciabile H400	400	378	9,0
<b>Art.13.0808D</b>	Posteriore DX rovesciabile H400	400	378	9,0
<b>Art.13.0808S</b>	Posteriore SX rovesciabile H400	400	378	9,0
<b>Art.13.0812D</b>	Anteriore DX da saldare H600	600	578	5,5
<b>Art.13.0812S</b>	Anteriore SX da saldare H600	600	578	5,5
<b>Art.13.0816</b>	Centrale rovesciabile H600	600	578	11,5
<b>Art.13.0818D</b>	Posteriore DX rovesciabile H600	600	578	11,5
<b>Art.13.0818S</b>	Posteriore SX rovesciabile H600	600	578	11,5
<b>Art.13.0822D</b>	Anteriore DX da saldare H800	800	778	6,5
<b>Art.13.0822S</b>	Anteriore SX da saldare H800	800	778	6,5
<b>Art.13.0826</b>	Centrale rovesciabile H800	800	778	12,5
<b>Art.13.0828D</b>	Posteriore DX rovesciabile H800	800	778	12,5
<b>Art.13.0828S</b>	Posteriore SX rovesciabile H800	800	778	12,5

MONTANTI CASSONE RIBALTABILE INNESTO A CUNEO SP. 38

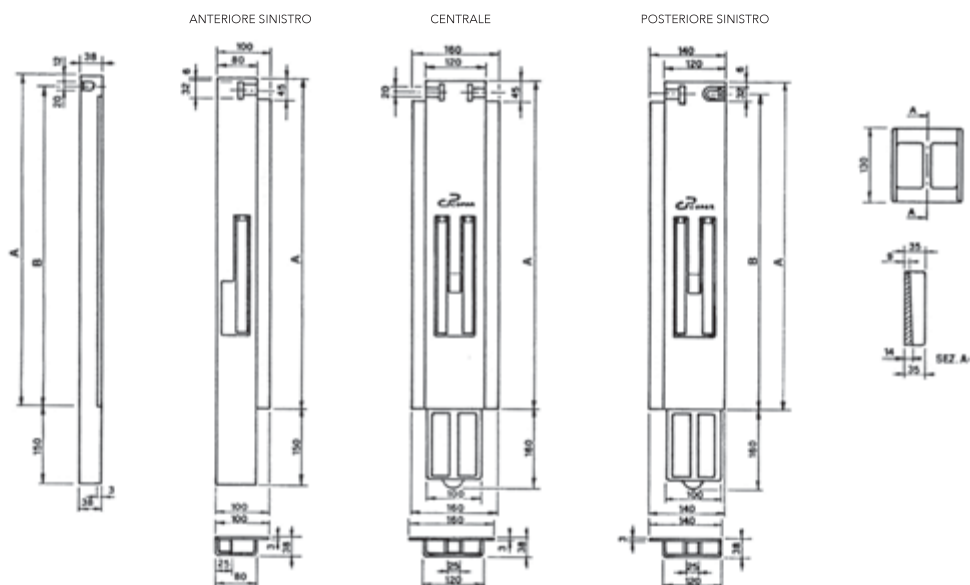

	Descrizione	A	B	kg
<b>Art.13.0924D</b>	Anteriore DX da saldare H500	500	478	5,9
<b>Art.13.0924S</b>	Anteriore SX da saldare H500	500	478	5,9
<b>Art.13.0926</b>	Centrale innesto cuneo H500	500	478	12,0
<b>Art.13.0928D</b>	Posteriore DX innesto cuneo H500	500	478	12,0
<b>Art.13.0928S</b>	Posteriore SX innesto cuneo H500	500	478	12,0
<b>Art.13.0934D</b>	Anteriore DX da saldare H600	600	578	6,9
<b>Art.13.0934S</b>	Anteriore SX da saldare H600	600	578	6,9
<b>Art.13.0936</b>	Centrale innesto cuneo H600	600	578	13,0
<b>Art.13.0938D</b>	Posteriore DX innesto cuneo H600	600	578	13,0
<b>Art.13.0938S</b>	Posteriore SX innesto cuneo H600	600	578	13,0
<b>Art.13.0944D</b>	Anteriore DX da saldare H800	800	778	8,0
<b>Art.13.0944S</b>	Anteriore SX da saldare H800	800	778	8,0
<b>Art.13.0946</b>	Centrale innesto cuneo H800	800	778	14,5
<b>Art.13.0948D</b>	Posteriore DX innesto cuneo H800	800	778	14,5
<b>Art.13.0948S</b>	Posteriore SX innesto cuneo H800	800	778	14,5

MONTANTI PER RIBALTABILI INNESTO A CUNEO

MONTANTI CASSONE RIBALTABILE INNESTO CUNEO SP. 44

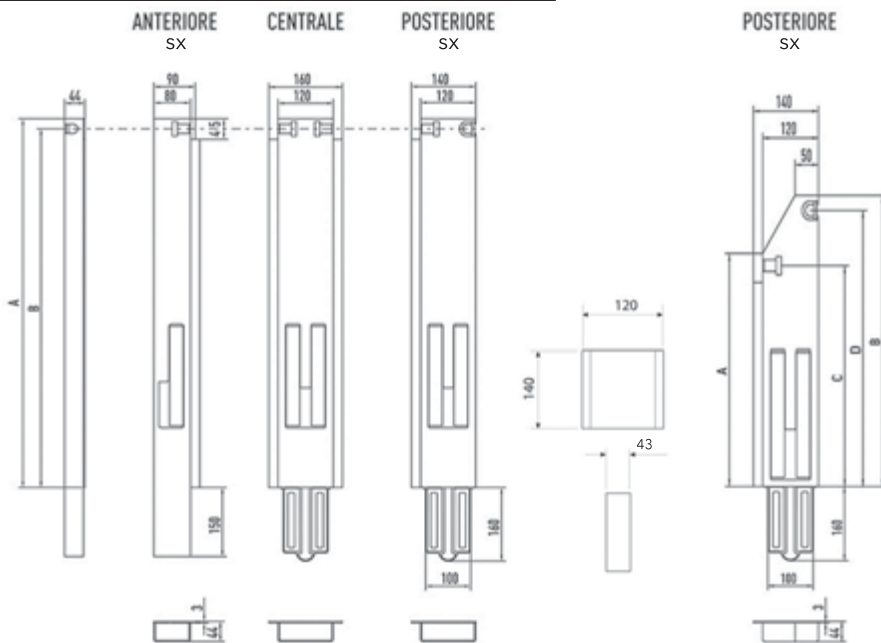

	Descrizione	A	B	kg
<b>Art.13.1200D</b>	Anteriore DX da saldare TR5 H400	400	378	5,1
<b>Art.13.1200S</b>	Anteriore SX da saldare TR5 H400	400	378	5,1
<b>Art.13.1202</b>	Centrale innesto cuneo TR5 H400	400	378	11,0
<b>Art.13.1203D</b>	Posteriore DX innesto cuneo TR5 H400	400	378	11,0
<b>Art.13.1203S</b>	Posteriore SX innesto cuneo TR5 H400	400	378	11,0
<b>Art.13.1203.1D</b>	Posteriore DX innesto cuneo TR5 H400/500	400	500	11,0
<b>Art.13.1203.1S</b>	Posteriore SX innesto cuneo TR5 H400/500	400	500	11,0
<b>Art.13.1204D</b>	Anteriore DX da saldare TR5 H500	500	478	6,0
<b>Art.13.1204S</b>	Anteriore SX da saldare TR5 H500	500	478	6,0
<b>Art.13.1206</b>	Centrale innesto cuneo TR5 H500	500	478	13,0
<b>Art.13.1207D</b>	Posteriore DX innesto cuneo TR5 H500	500	478	13,0
<b>Art.13.1207S</b>	Posteriore SX innesto cuneo TR5 H500	500	478	13,0
<b>Art.13.1207.1D</b>	Posteriore DX innesto cuneo TR5 H500/600	500	600	13,0
<b>Art.13.1207.1S</b>	Posteriore SX innesto cuneo TR5 H500/600	500	600	13,0

MONTANTI CASSONE RIBALTABILE INNESTO CUNEO SP. 44

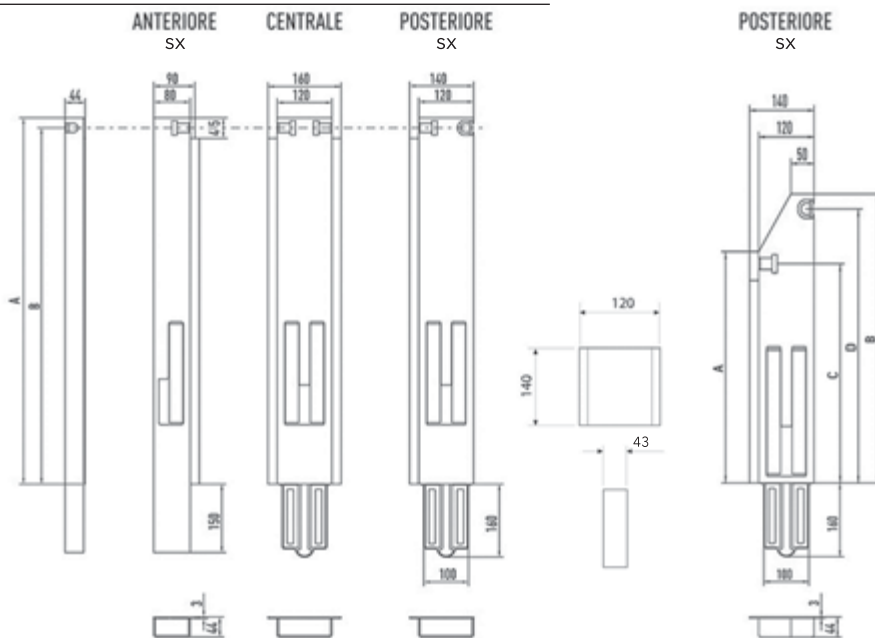

	Descrizione	A	B	kg
<b>Art.13.1208D</b>	Anteriore DX da saldare TR5 H600	600	578	6,5
<b>Art.13.1208S</b>	Anteriore SX da saldare TR5 H600	600	578	6,5
<b>Art.13.1210</b>	Centrale innesto cuneo TR5 H600	600	578	16,0
<b>Art.13.1211D</b>	Posteriore DX innesto cuneo TR5 H600	600	578	16,0
<b>Art.13.1211S</b>	Posteriore SX innesto cuneo TR5 H600	600	578	16,0
<b>Art.13.1211.1D</b>	Posteriore DX innesto cuneo TR5 H600/700	600	700	16,0
<b>Art.13.1211.1S</b>	Posteriore SX innesto cuneo TR5 H600/700	600	700	16,0
<b>Art.13.1222D</b>	Anteriore DX da saldare TR5 H800	800	778	8,0
<b>Art.13.1222S</b>	Anteriore SX da saldare TR5 H800	800	778	8,0
<b>Art.13.1226</b>	Centrale innesto cuneo TR5 H800	800	778	18,0
<b>Art.13.1228D</b>	Posteriore DX innesto cuneo TR5 H800	800	778	18,0
<b>Art.13.1228S</b>	Posteriore SX innesto cuneo TR5 H800	800	778	18,0
<b>Art.13.1228.1D</b>	Posteriore DX innesto cuneo TR5 H800/900	800	900	18,0
<b>Art.13.1228.1S</b>	Posteriore SX innesto cuneo TR5 H800/900	800	900	18,0

SOVRAMONTANTI PER APERTURA TRILATERALE 180°

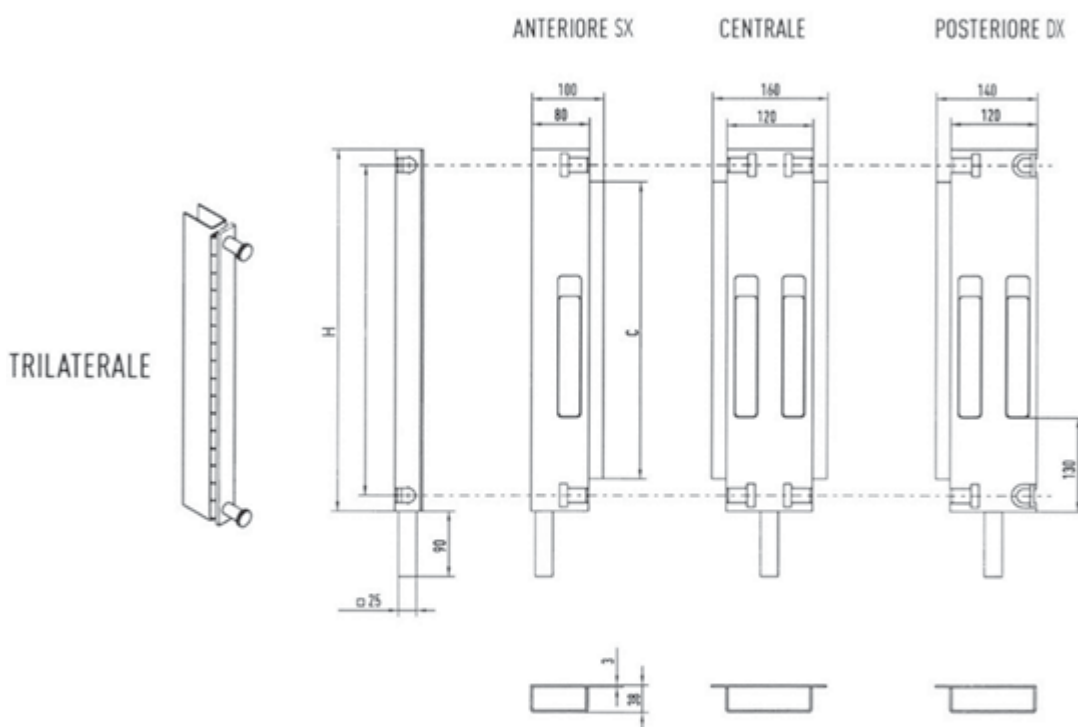

H:400	H:500	H:600	H:800	Descrizione		L
Art.13.2000	Art.13.2020	Art.13.2040	Art.13.2060	Anteriore ferro inox	DX	80
Art.14.2000	Art.14.2020	Art.14.2040	Art.14.2060	Anteriore ferro inox	SX	80
Art.13.2002	Art.13.2022	Art.13.2042	Art.13.2062	Centrale ferro inox		120
Art.14.2002	Art.14.2022	Art.14.2042	Art.14.2062	Posteriore ferro inox	DX	120
Art.13.2010	Art.13.2030	Art.13.2050	Art.13.2070	Posteriore ferro inox	SX	120
Art.14.2010	Art.14.2030	Art.14.2050	Art.14.2070			
Art.13.2012	Art.13.2032	Art.13.2052	Art.13.2072			
Art.14.2012	Art.14.2032	Art.14.2052	Art.14.2072			

TESTATE ZINCATE SPONDE mm 25



	Descrizione	kg
<b>Art.13.1300</b>	Testata zinc. H400	1,0
<b>Art.13.1301</b>	Testata zinc. H500	1,3
<b>Art.13.1302</b>	Testata zinc. H600	1,5
<b>Art.13.1304</b>	Testata zinc. H800	1,8

TESTATE ZINCATE 400/500 SPONDE mm 25

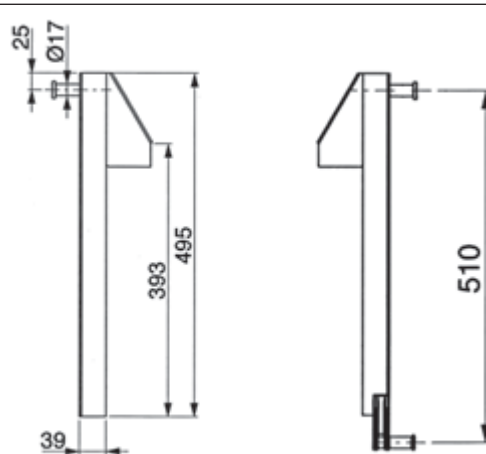

	Descrizione	kg
<b>Art.13.1510</b>	Testata zincata	1,3
<b>Art.13.1512</b>	Testata zinc. c/cerniera	1,5

TESTATE ZINCATE SPONDE mm 25



	Descrizione	kg
<b>Art.13.2100</b>	Testata poker H400	2,0
<b>Art.13.2120</b>	Testata poker H500	2,3
<b>Art.13.2140</b>	Testata poker H600	2,7
<b>Art.13.2160</b>	Testata poker H800	3,0

TESTATE ZINCATE SPONDE mm 25



	Descrizione	kg
<b>Art.13.2200</b>	Testata fissa H400	1,2
<b>Art.13.2220</b>	Testata fissa H500	1,3
<b>Art.13.2240</b>	Testata fissa H600	1,5
<b>Art.13.2260</b>	Testata fissa H800	1,9

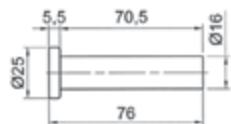

**Art.13.0020**

Perno acciaio grezzo kg 0,13

**Art.13.0021**

Perno acciaio zincato kg 0,13

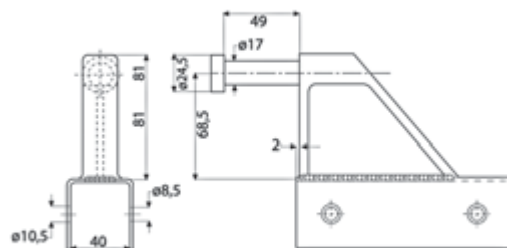

**Art.13.0018**

Piantone zincato con supporto serie TR5 kg 1,80

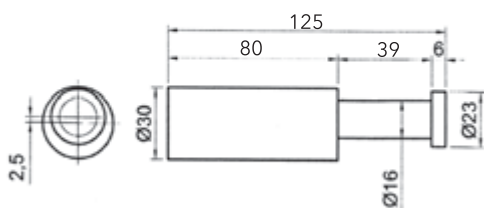

**Art.13.0019**

Perno zincato posteriore serie TR5 kg 0,80

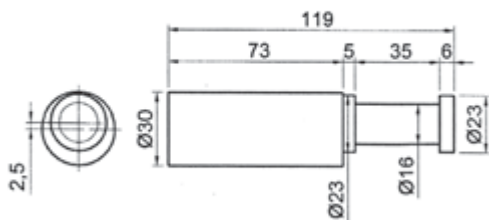

**Art.13.1921**

Perno zincato laterale eccentrico serie TR5 kg 0,50

TESTATE ZINCATE E ALLUMINIO SERIE TR5

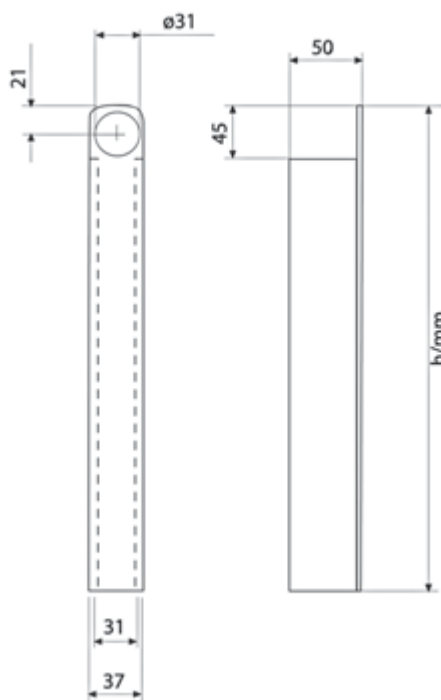

Zincate	Alluminio	H	kg
Art.14.0045	Art.14.0045.2	400	1,00
Art.14.0047.1	Art.14.0047.2	500	1,30
Art.14.0042.1	Art.14.0042.2	600	1,60
Art.14.0043.1	Art.14.0043.2	800	2,10

Art.14.0045	Art.14.0045.2	400	1,00
Art.14.0047.1	Art.14.0047.2	500	1,30
Art.14.0042.1	Art.14.0042.2	600	1,60
Art.14.0043.1	Art.14.0043.2	800	2,10

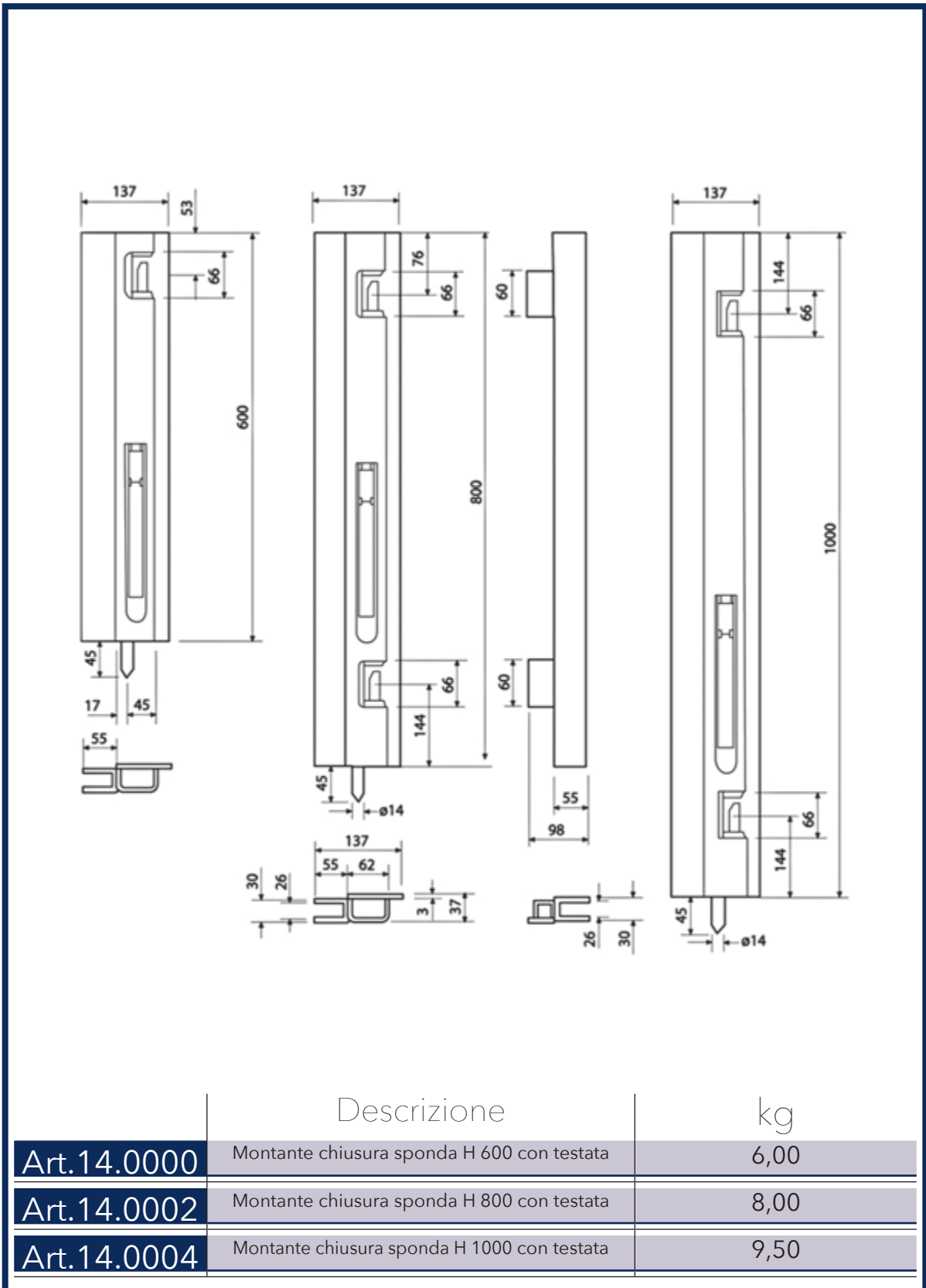

MONTANTI PER CHIUSURE SPONDE POSTERIORI



MONOPROFILO

MOD P.P.A.

MOD T.P.A.

BOMBATO C/ALA

TR30

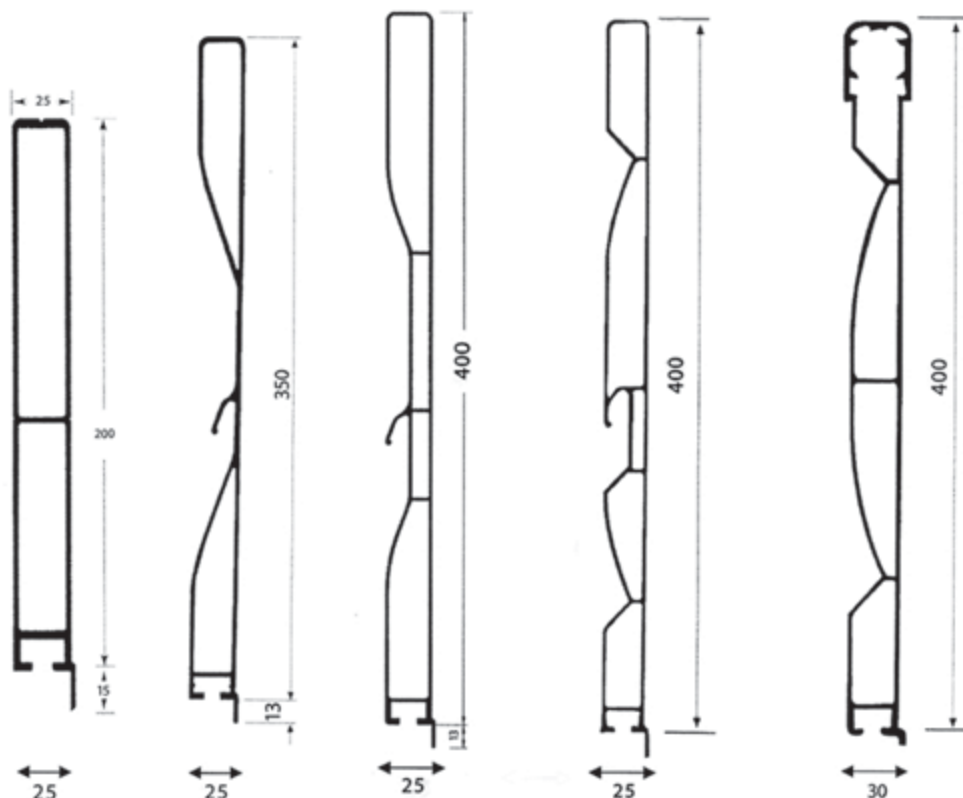

	Descrizione	L mm	kg/m
<b>Art.99.0002</b>	Monoprofilo H 200 25 mm	7500	2,70
<b>Art.99.0026</b>	Monoprofilo H 350 25 mm	7500	3,50
<b>Art.99.0027</b>	Monoprofilo H 400 mod. TPA 25 mm	6000	4,40
<b>Art.99.0028</b>	Monoprofilo H 400 mod. TPA 25 mm	6600	4,40
<b>Art.99.0029</b>	Monoprofilo H 400 mod. TPA 25 mm	7500	4,40
<b>Art.99.0006</b>	Monoprofilo H 400 bombato 25 mm	6600	5,20
<b>Art.99.0008</b>	Monoprofilo H 400 bombato 25 mm	7500	5,20
<b>Art.99.8600</b>	Monoprofilo H 400 TR30 30 mm	6100	7,50
<b>Art.99.8602</b>	Monoprofilo H 400 TR30 30 mm	6600	7,50



	L	Descrizione	kg/m
<b>Art.99.0082</b>	6,0 m	Profilo testata senza battuta mm 25,5	0,76
<b>Art.99.0092</b>	6,0 m	Profilo testata senza battuta mm 30,5	1,00

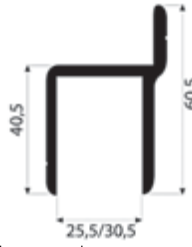

	L	Descrizione	kg/m
<b>Art.99.0080</b>	6,0 m	Profilo testata con battuta mm 25,5	1,01
<b>Art.99.0094</b>	6,0 m	Profilo testata con battuta mm 30,5	1,00

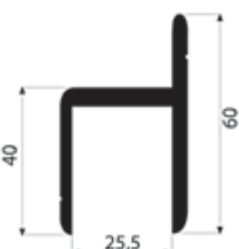

	L	Descrizione	kg/m
<b>Art.99.0086</b>	6,0 m	Profilo testata con battuta piatta	1,01

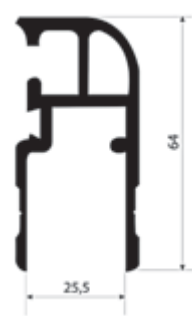

	L	Descrizione	kg/m
<b>Art.99.0078</b>	6,6 m	Profilo testata	1,20

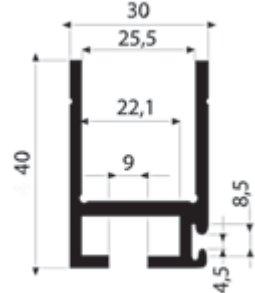

	L	Descrizione	kg/m
<b>Art.99.0084</b>	6,0 m	Profilo testata con feritoia	0,99



	Descrizione	gr.
<b>Art.99.0090</b>	Guarnizione in gomma	7,00

PROFILI IN ALLUMINIO PER SPONDE

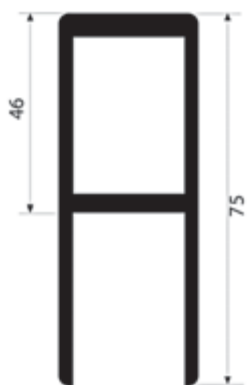

	L	Descrizione	kg/m
<b>Art.99.0085</b>	6,0 m	Profilo testata	1,30



	L	Descrizione	kg/m
<b>Art.99.0081</b>	6,0 m	Profilo estremità largo	1,615

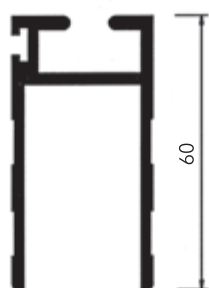

	L	Descrizione	kg/m
<b>Art.99.0084.1</b>	6,0 m	Profilo con feritoia largo	1,07

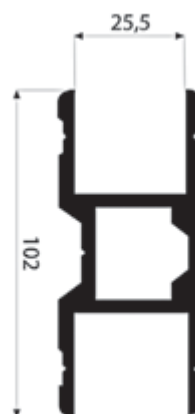

	L	Descrizione	kg/m
<b>Art.99.0088</b>	6,0 m	Profilo H	2,00

PROFILI SUPERIORI mm 25 SERIE TS

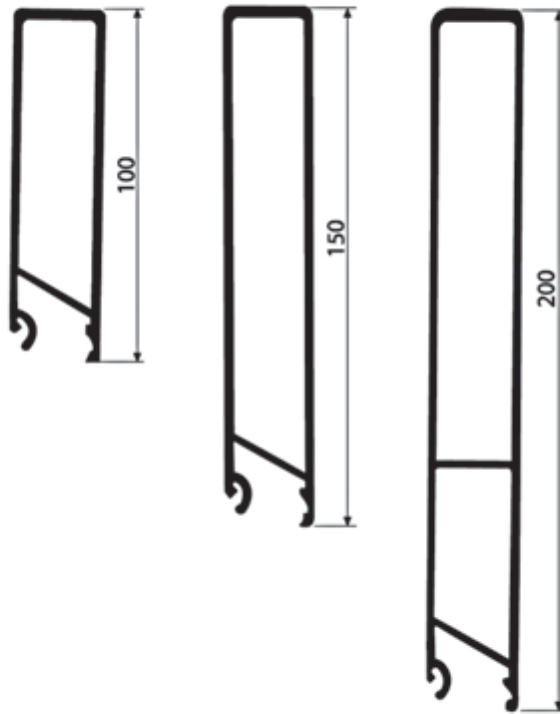

7,5 m	6,6 m	6,0 m	Descrizione	kg/m
Art.99.7502			Superiore 100 mm	1,25
Art.99.7504			Superiore 150 mm	1,75
Art.99.7506	Art.99.6606	Art.99.6006	Superiore 200 mm	2,35

PROFILI INTERMEDI mm 25 SERIE TS

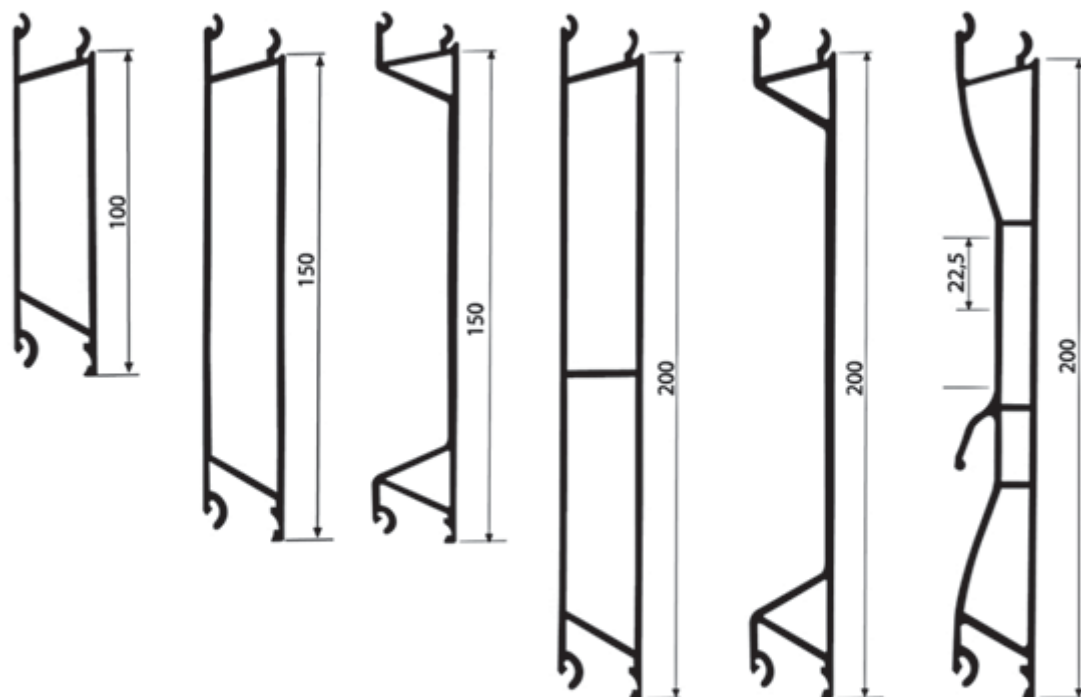

7,5 m	6,6 m	6,0 m	Descrizione	kg/m
Art.99.7508			Intermedio 100 mm	1,40
Art.99.7510			Intermedio 150 mm	1,80
Art.99.7512			Intermedio TIR 150 mm	1,70
Art.99.7514	Art.99.6614	Art.99.6014	Intermedio 200 mm	2,60
Art.99.7516	Art.99.6616	Art.99.6016	Intermedio TIR 200 mm	2,20
Art.99.7518	Art.99.6618	Art.99.6018	Intermedio con aletta 200 mm	2,60

PROFILI INFERIORI mm 25 SERIE TS

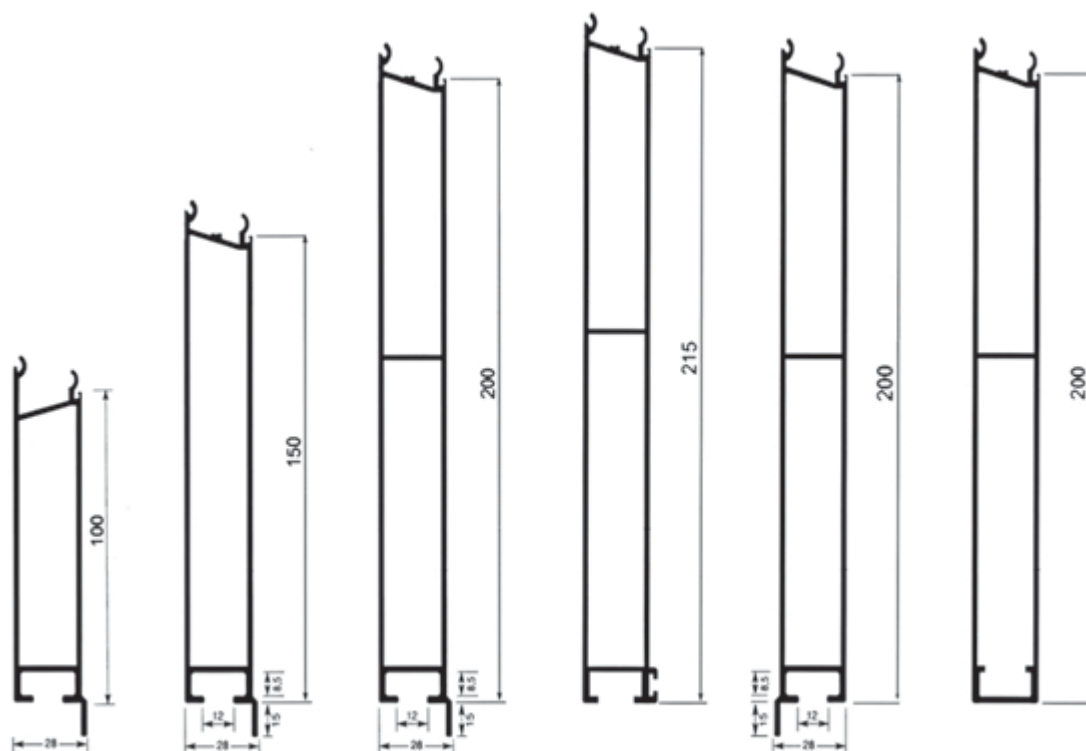

7,5 m	6,6 m	6,0 m	Descrizione	kg/m
Art.99.7528			Inferiore 100 mm	1,80
Art.99.7520			Inferiore 150 mm	2,70
Art.99.7522	Art.99.6622	Art.99.6022	Inferiore 200 mm	3,50
Art.99.7524	Art.99.6624	Art.99.6024	Inferiore 215 mm con guarnizione	4,40
Art.99.7526			Inferiore 200 mm con battuta contraria	4,40
Art.99.7532			Inferiore 200 mm chiuso	4,40

PROFILI SUPERIORI mm 25 SERIE TR1

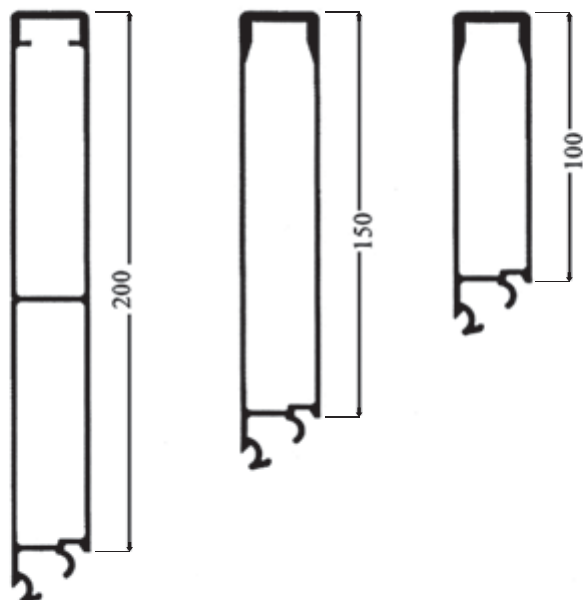

7,5 m	6,6 m	6,0 m	Descrizione	kg/m
Art.99.4706	Art.99.4606	Art.99.4006	Superiore 200 mm	2,46
Art.99.4704	Art.99.4604		Superiore 150 mm	2,03
Art.99.4702	Art.99.4602		Superiore 100 mm	1,60

PROFILI SUPERIORI mm 25 SERIE TR1

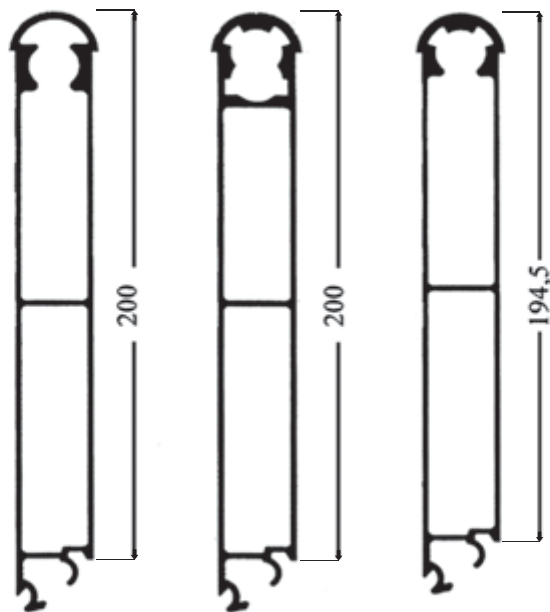

7,5 m	6,6 m	6,0 m	Descrizione	kg/m
Art.99.4730			Superiore 200 mm	2,70
Art.99.4732			Superiore 200 mm doppio foro	3,10
Art.99.4734			Superiore 194,5 mm	2,65



PROFILI INTERMEDI mm 25 SERIE TR1

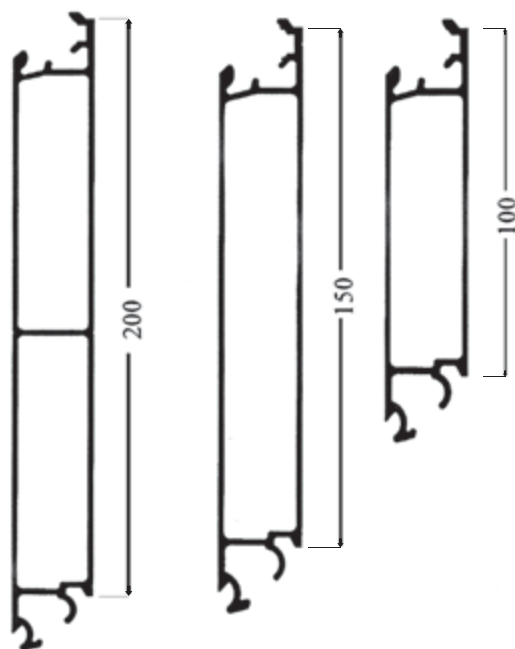

7,5 m	6,6 m	6,0 m	Descrizione	kg/m
Art.99.4714	Art.99.4614	Art.99.4014	Intermedio 200 mm	2,45
Art.99.4710	Art.99.4610		Intermedio 150 mm	1,90
Art.99.4708			Intermedio 100 mm	1,50

PROFILI INTERMEDI mm 25 SERIE TR1

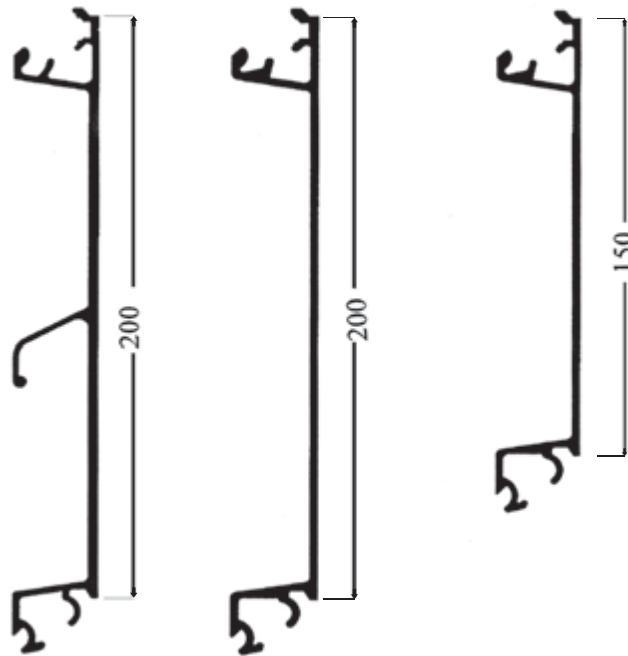

7,5 m	6,6 m	6,0 m	Descrizione	kg/m
Art.99.4718	Art.99.4618	Art.99.4018	TIR c/ala 200 mm	2,50
Art.99.4716	Art.99.4616	Art.99.4016	TIR 200 mm	1,85
Art.99.4712			TIR 150 mm	1,75

PROFILI INFERIORI mm 25 SERIE TR1

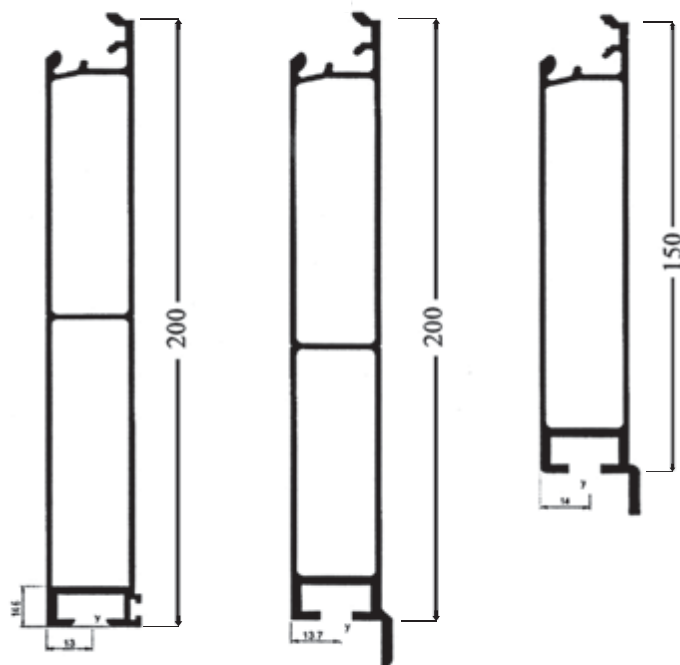

7,5 m	6,6 m	6,0 m	Descrizione	kg/m
Art.99.4724	Art.99.4624	Art.99.4024	Inferiore C/Guarnizione 200 mm	2,55
Art.99.4722	Art.99.4622	Art.99.4022	Inferiore 200 mm	2,55
Art.99.4720			Inferiore 150 mm	2,00

PROFILI INFERIORI mm 25 SERIE TR1

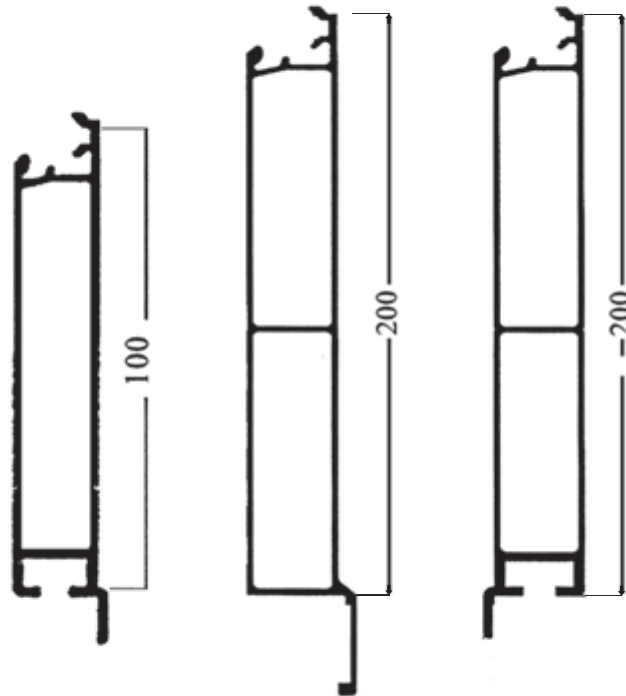

7,5 m	6,6 m	6,0 m	Descrizione	kg/m
Art.99.4728			Inferiore 100 mm	1,60
Art.99.4740			Inferiore 200 mm per sovrasponde	2,50
Art.99.4726			Inferiore 200 mm aletta contraria	2,55

PROFILI INFERIORI mm 25 SERIE TR1

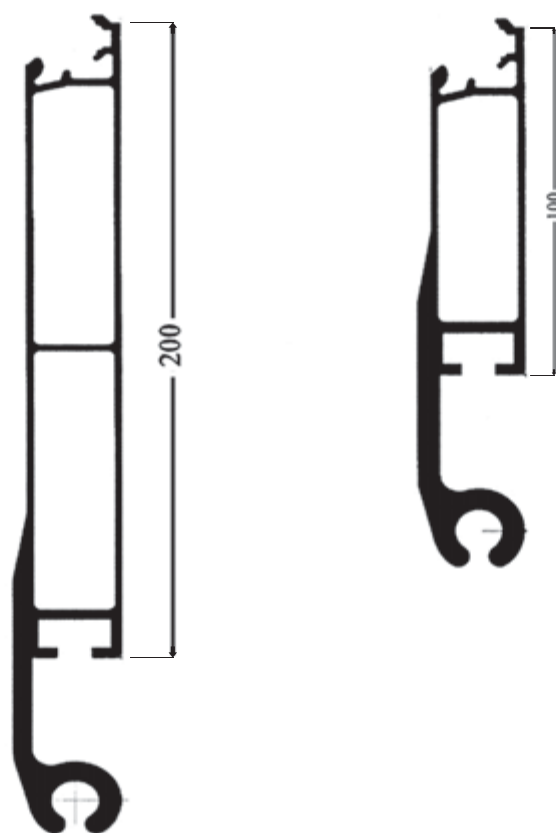

7,5 m	6,6 m	6,0 m	Descrizione	kg/m
Art.99.4742			Inferiore 200 mm con cerniera	4,40
Art.99.4744			Inferiore 100 mm con cerniera	3,40

PROFILI mm 25 SERIE TR6

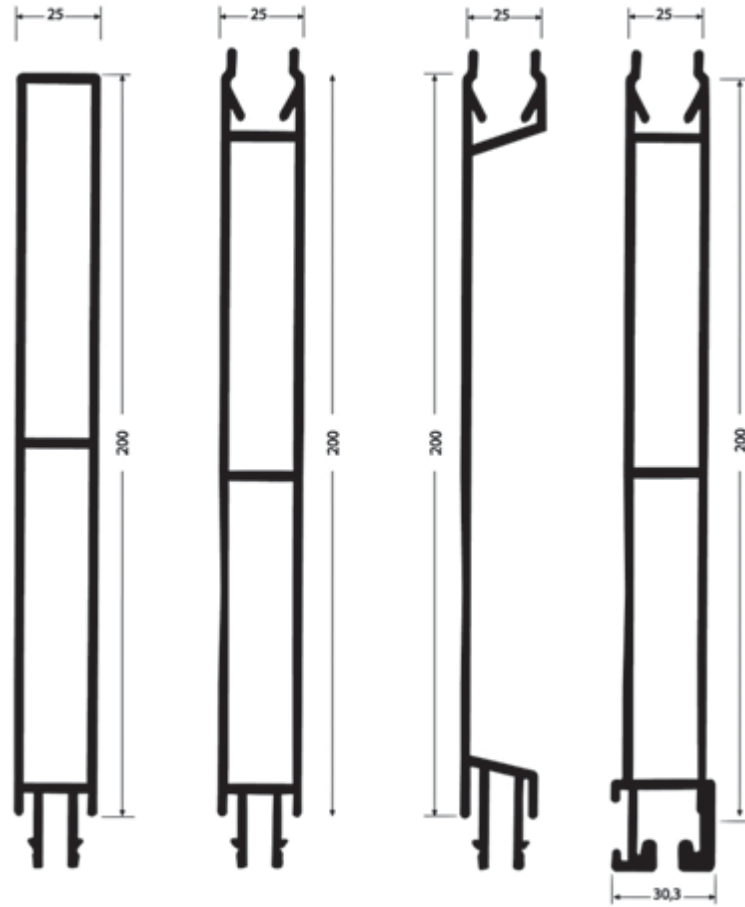

	Descrizione	L mm	kg/m
<b>Art.99.8806</b>	Profilo superiore TR6 200 mm	6600	2,50
<b>Art.99.8814</b>	Profilo intermedio TR6 200 mm	6600	2,30
<b>Art.99.8816</b>	Profilo Tir intermedio TR6 200 mm	6600	2,10
<b>Art.99.8824</b>	Profilo inferiore TR6 200 mm	6600	2,80

PROFILI mm 30 SERIE TR30

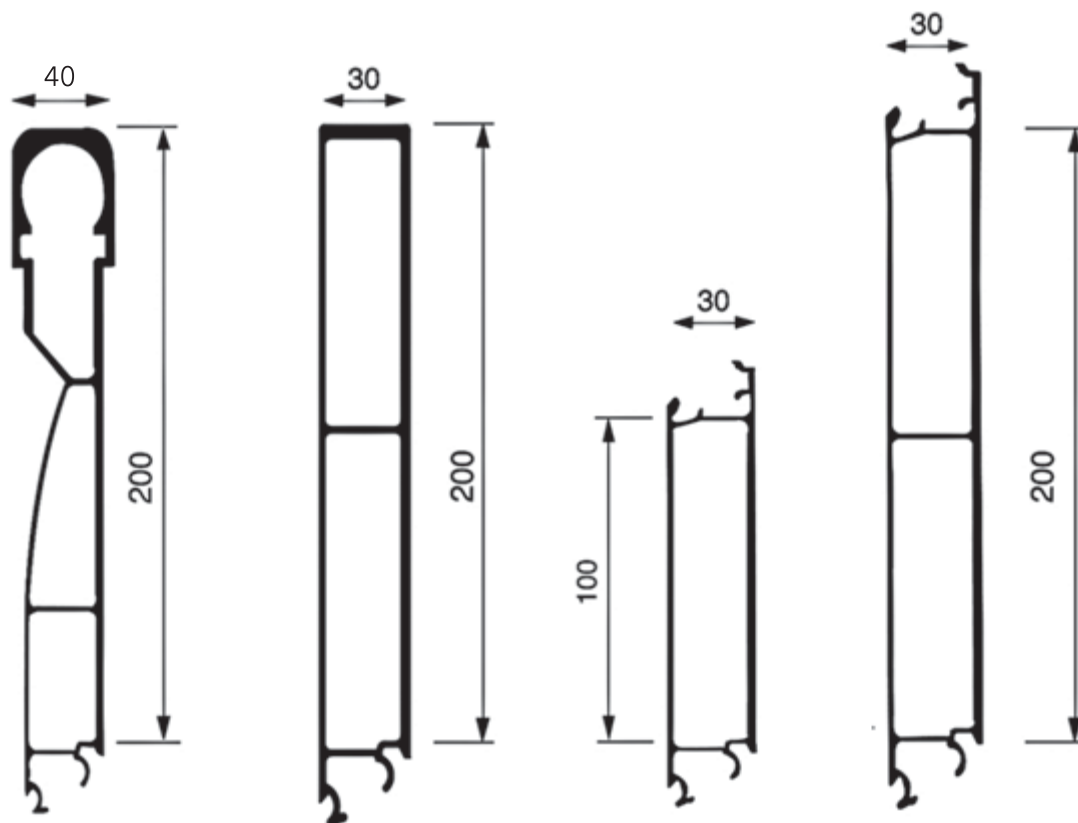

7,5 m	6,6 m	6,2 m	Descrizione	kg/m
Art.99.5702	Art.99.5662	Art.99.5602	Profilo superiore bombato 200 mm	4,70
Art.99.5700	Art.99.5660		Profilo superiore 200 mm	3,50
Art.99.5704	Art.99.5664	Art.99.5604	Profilo intermedio 100 mm	1,80
Art.99.5706	Art.99.5666	Art.99.5606	Profilo intermedio 200 mm	3,20

PROFILI mm 30 SERIE TR30

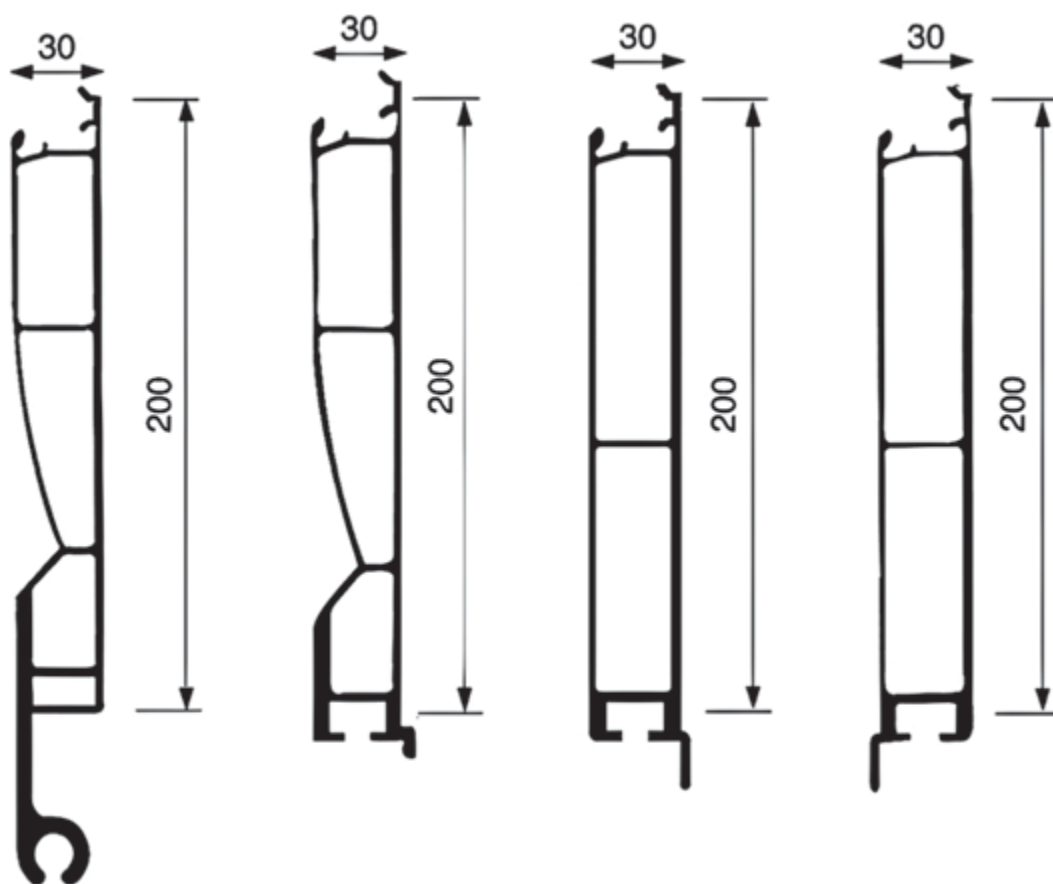

7,5 m	6,6 m	6,2 m	Descrizione	kg/m
Art.99.5708	Art.99.5668	Art.99.5608	Profilo inferiore con cerniera 200 mm	5,30
Art.99.5710	Art.99.5670	Art.99.5610	Profilo inferiore bombato 200 mm	4,00
Art.99.5714	Art.99.5674		Profilo inferiore 200 mm	3,60
Art.99.5712	Art.99.5672		Profilo inferiore contrario 200 mm	3,60



PROFILI mm 30 SERIE TR5

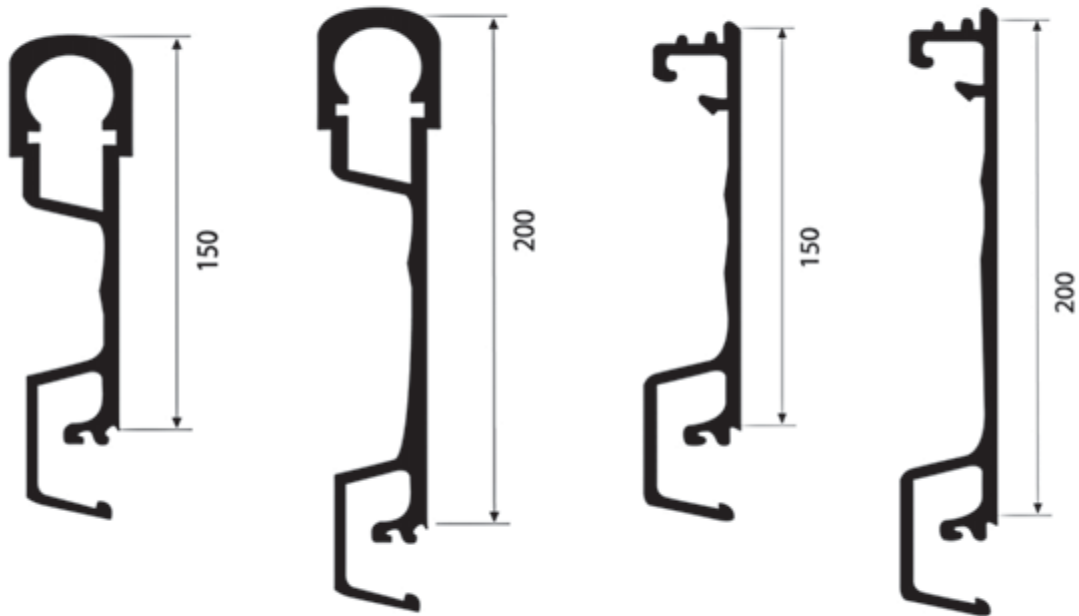

7,5 m	6,6 m	6,0 m	Descrizione	kg/m
Art.99.8702			Profilo superiore 150 mm	4,10
Art.99.8706	Art.99.8630	Art.99.8606	Profilo superiore 200 mm	4,70
Art.99.8710			Profilo intermedio 150 mm	2,80
Art.99.8714	Art.99.8632	Art.99.8614	Profilo intermedio 200 mm	3,40

PROFILI mm 30 SERIE TR5

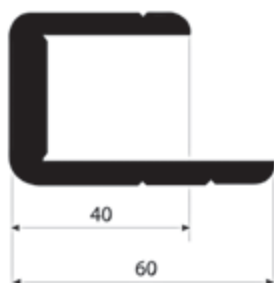

Art.99.0096

Profilo testata per sponde TR5 L 6000 kg/m 1,70

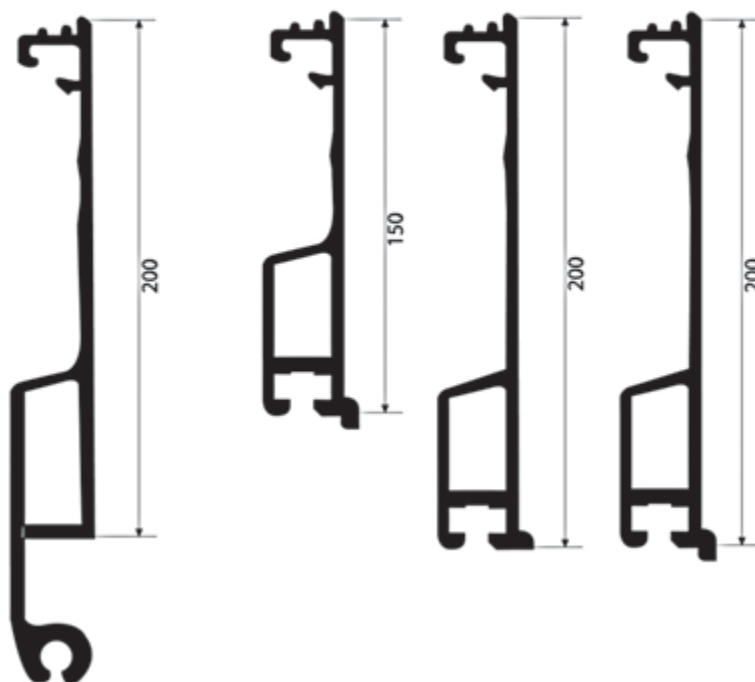

7,5 m	6,6 m	6,0 m	Descrizione	kg/m
Art.99.8726		Art.99.8626	Profilo inferiore con cerniera 200 mm	5,30
Art.99.8720			Profilo inferiore 150 mm	3,40
Art.99.8722			Profilo inferiore con aletta orizz. 200 mm	3,90
Art.99.8724	Art.99.8636	Art.99.8624	Profilo inferiore 200 mm	3,90

SPESSORE mm25

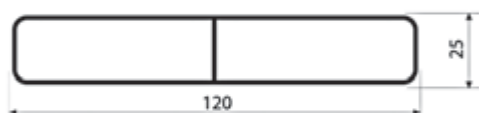

	L	Tipo	kg/m
Art.99.0036	6,6 m	Grezzo	1,60
Art.99.0038	7,5 m	Grezzo	1,60
Art.99.0036.1	6,6 m	Anodizzato	1,60

SPESSORE mm25



Grezzo	Anodizzato	L	kg/m
Art.99.0039	Art.99.0039.1	6,0 m	1,05
Art.99.0040	Art.99.0040.1	6,6 m	1,05
Art.99.0042	Art.99.0042.1	7,6 m	1,05

SPESSORE mm30

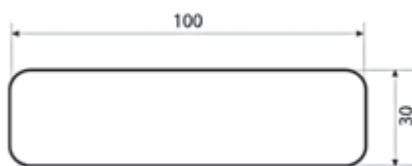

	L	Tipo	kg/m
Art.99.0034	7,5 m	Grezzo	1,40

SPESSORE mm25

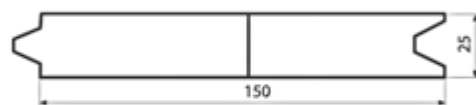

	L	Tipo	kg/m
Art.99.0045	6,0 m	Grezzo	1,86
Art.99.0046	6,6 m	Grezzo	1,86
Art.99.0044	7,5 m	Grezzo	1,86
Art.99.0046.1	6,6 m	Anodizzato	1,86

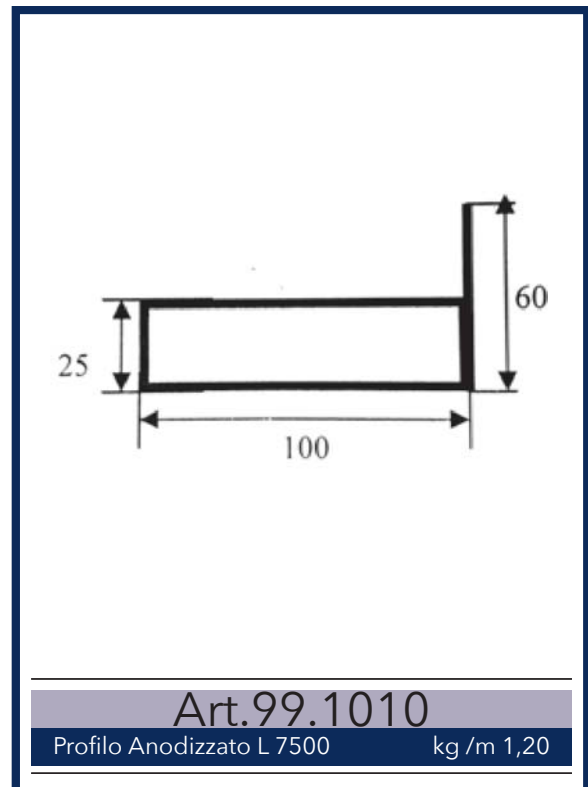
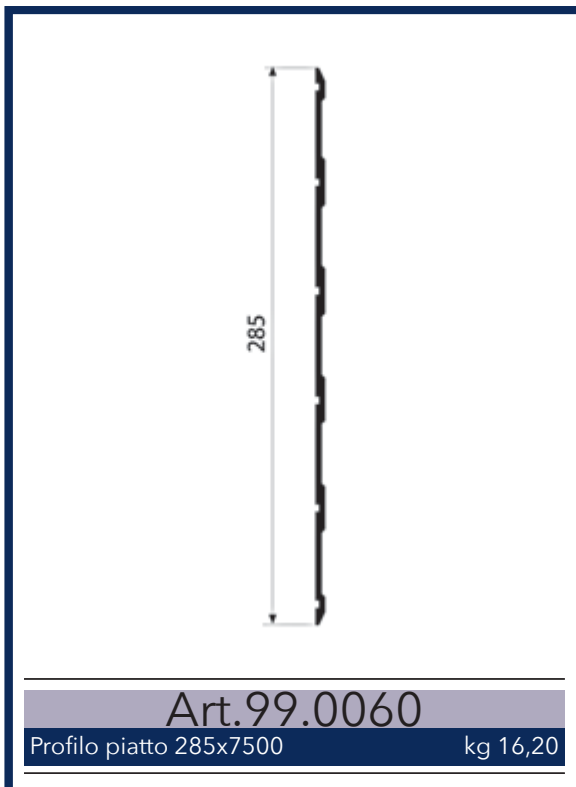
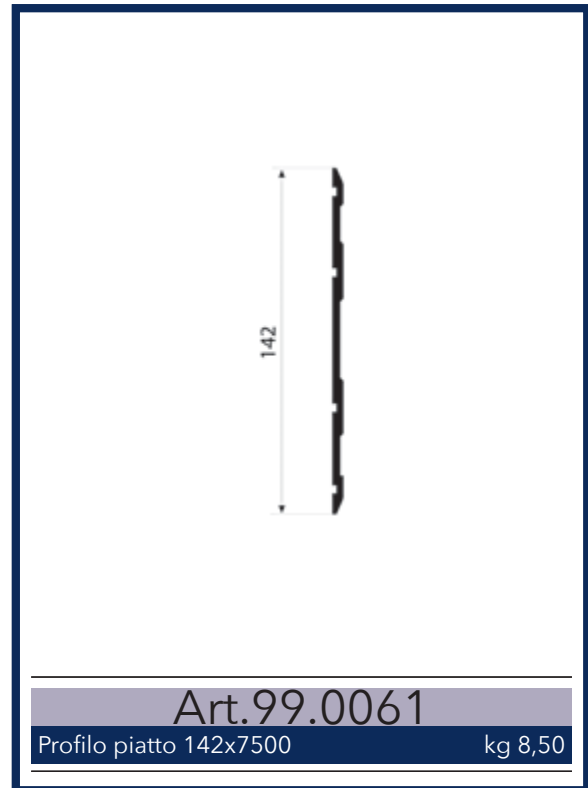
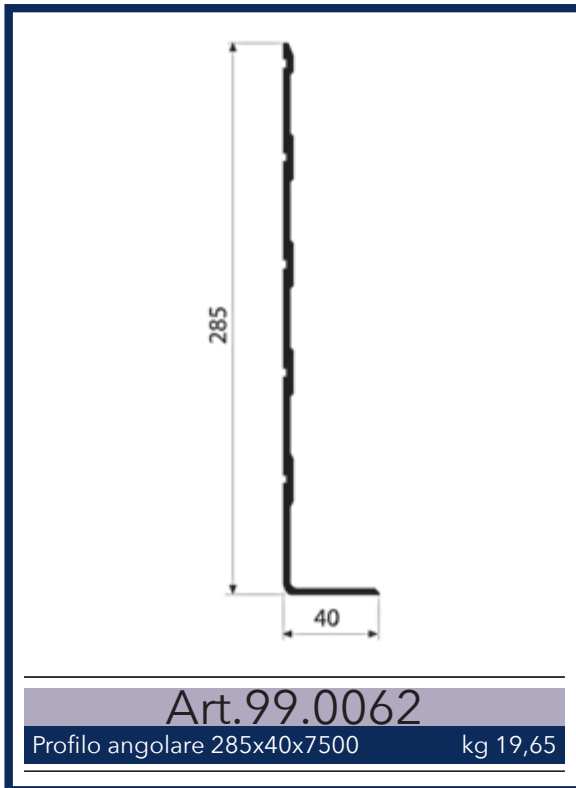

PROFILI PER ISOTERMICI

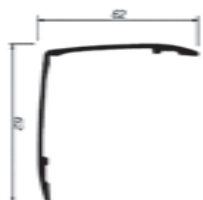

**Art.99.0074**

Profilo angolare 60x60 L 7500 kg 4,70



**Art.99.0075**

Profilo angolare 60x80 L 7500 kg 7,20



**Art.99.0076**

Profilo angolare 60x100 L 7500 kg 9,00



**Art.99.0068**

Profilo angolare 60x70x60 L 6000 kg 8,50

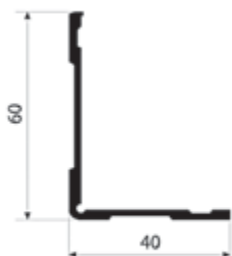

**Art.99.0070**

Profilo angolare 60x40 L 7500 kg 4,30



**Art.99.0072**

Profilo angolare 60x80 L 7500 kg 7,20

PROFILI PER ISOTERMICI

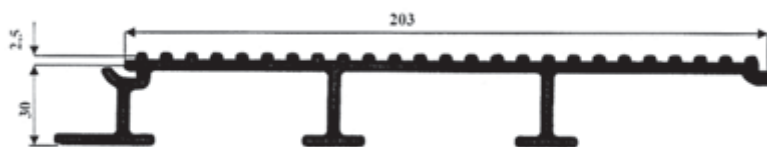

Art.99.1001

Profilo pianale H 30 lega 6060 L 7,5 m kg/m 2,94

Art.99.1001.1

Profilo pianale H 30 lega 6060 L 6,6 m kg/m 2,94

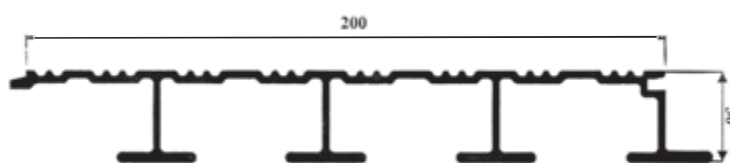

Art.99.1003

Profilo pianale H 30 lega 6060 L 7,5 m kg/m 3,20

Art.99.1003.1

Profilo pianale H 30 lega 6060 L 6,6 m kg/m 3,20

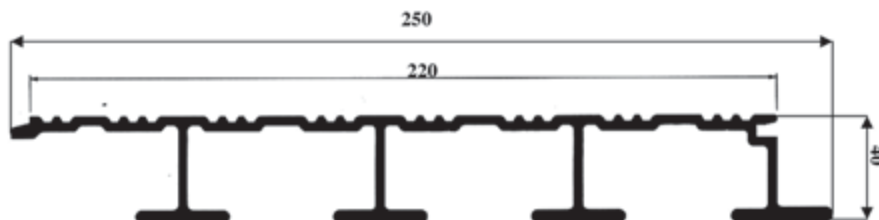

Art.99.1005

Profilo pianale H 40 lega 6060 L 7,5 m kg/m 4,40

Art.99.1005.1

Profilo pianale H 40 lega 6060 L 6,6 m kg/m 4,40

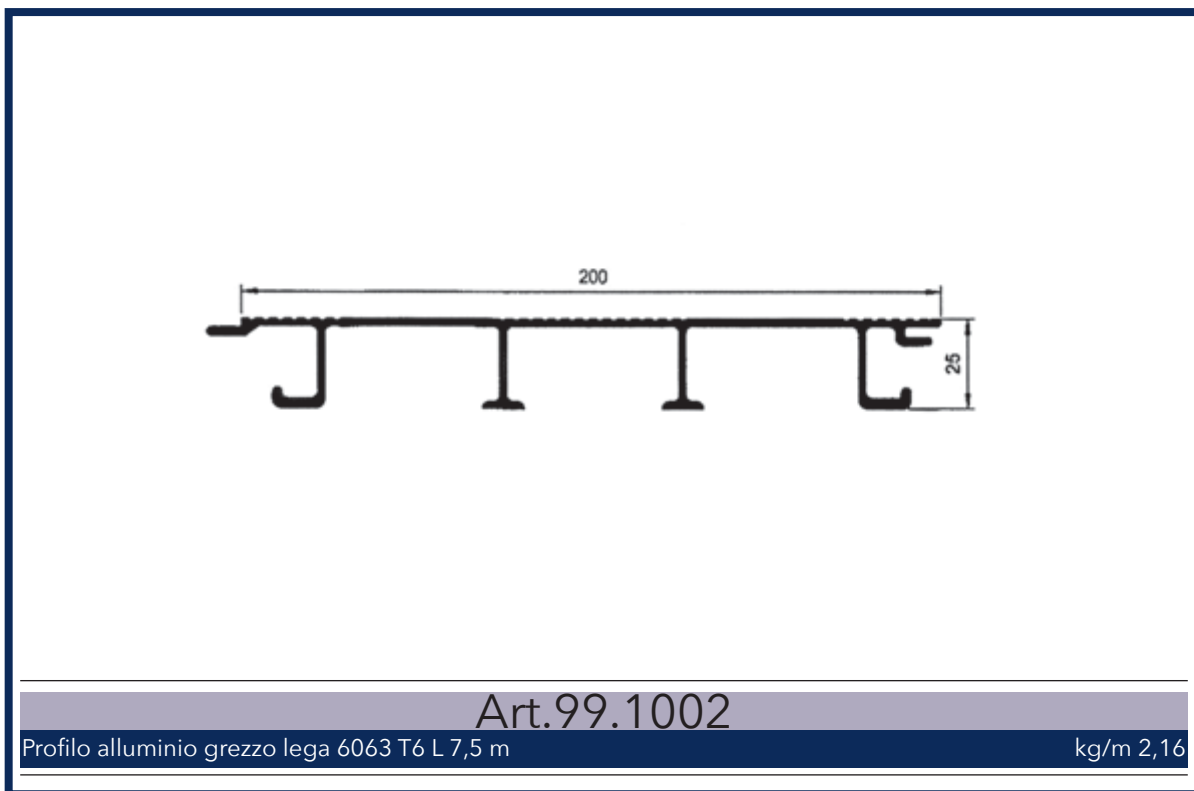
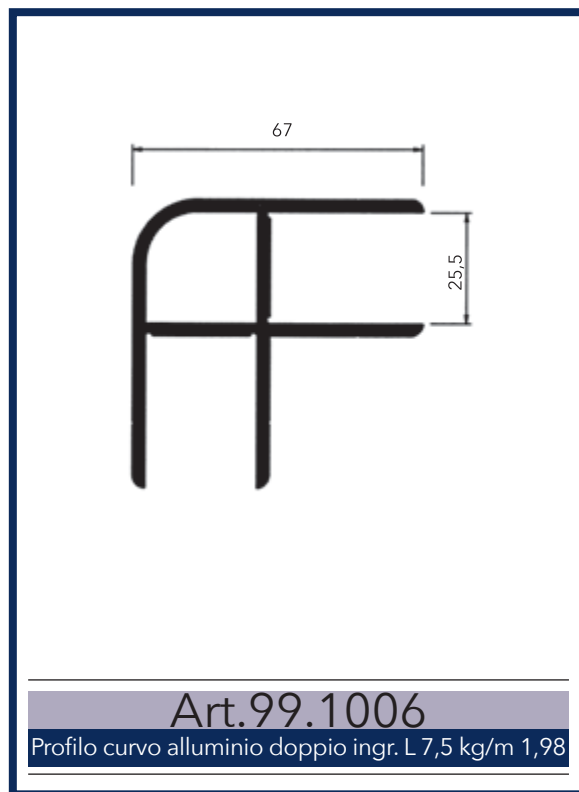
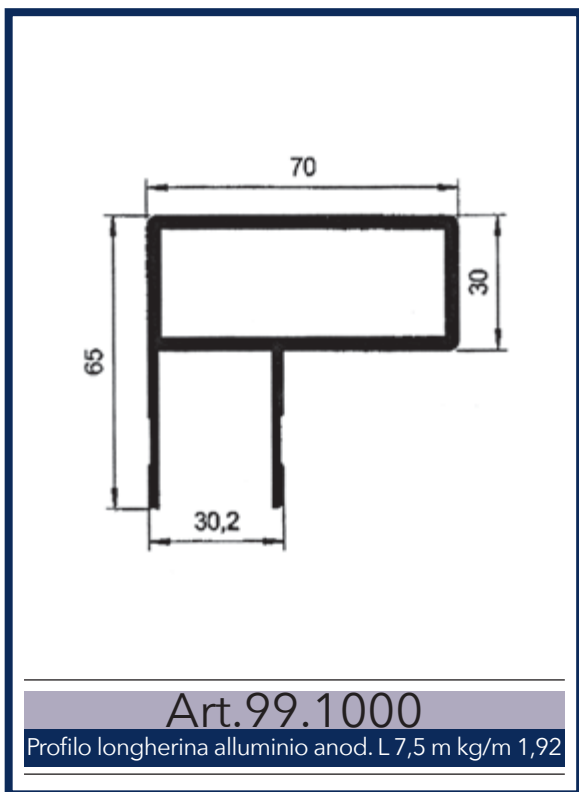

ALLUMINIO MANDORLATO



	Lega 1050	
	Dimensioni	kg/foglio
<b>Art.99.0050</b>	2000x1000x2	12,75
<b>Art.99.0052</b>	2000x1000x3	18,15
<b>Art.99.0054</b>	2500x1250x2	18,55
<b>Art.99.0056</b>	2500x1250x3	28,47
<b>Art.99.0057</b>	3000x1500x2	28,53
<b>Art.99.0057.1</b>	3000x1500x3	37,00
<b>Art.99.0058</b>	4500x2100x2	59,00
<b>Art.99.0055</b>	6000x2000x3	105,00
Lega 5754 Peralluman		
<b>Art.99.0162</b>	2500x1250x2	18,55
<b>Art.99.0164</b>	2500x1250x3	28,47
<b>Art.99.0166</b>	3000x1500x2	28,53
<b>Art.99.0168</b>	3000x1500x3	37,00
<b>Art.99.0172</b>	3000x1500x5	70,00



ALLUMINIO LISCIO



Lega 1050

	Dimensioni	kg/foglio
Art.99.0102	2000x1000x2	10,80
Art.99.0110	2500x1250x1	8,50
Art.99.0112	2500x1250x2	16,87
Art.99.0114	2500x1250x3	25,38
Art.99.0120	3000x1500x1	8,50
Art.99.0122	3000x1500x2	26,40
Art.99.0124	3000x1500x3	36,45

Lega 5754 Peralluman

Art.99.0150	2500x1250x2	16,85
Art.99.0152	2500x1250x3	25,38
Art.99.0154	3000x1500x2	26,40
Art.99.0156	3000x1500x3	36,45
Art.99.0158	3000x1500x4	48,60
Art.99.0159	3000x1500x5	63,50

GRANA DI RISO



Lega 5058

Dimensioni

kg/foglio

**Art.99.0059**

2500x1250x1,5

14,00

LAMIERA INOX FIORETTATO

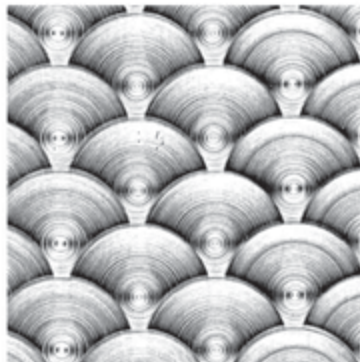

Lega A 304

Dimensioni

kg/foglio

**Art.99.2004**

2500x1250x1

26

**Art.99.2006**

2500x1250x1,5

38

**Art.99.2010**

3000x1500x1

37

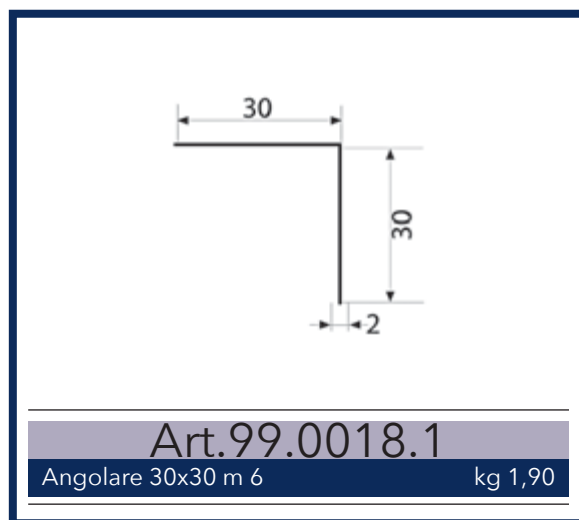
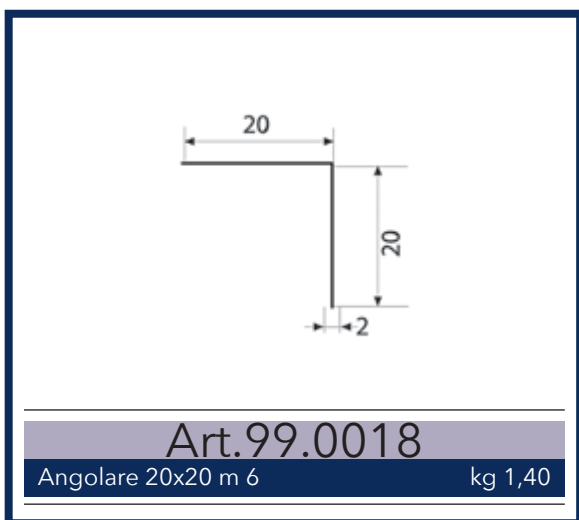
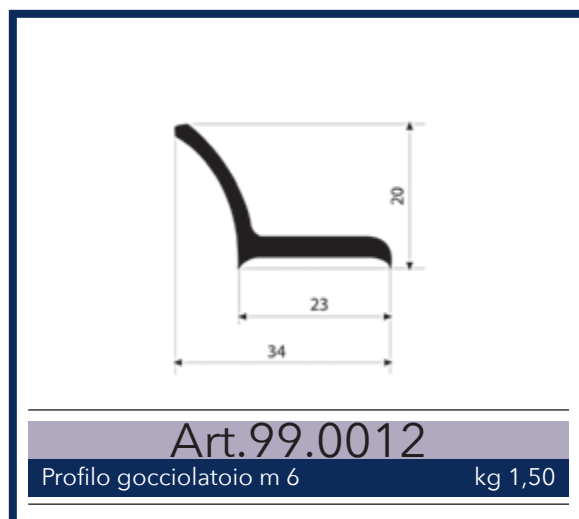
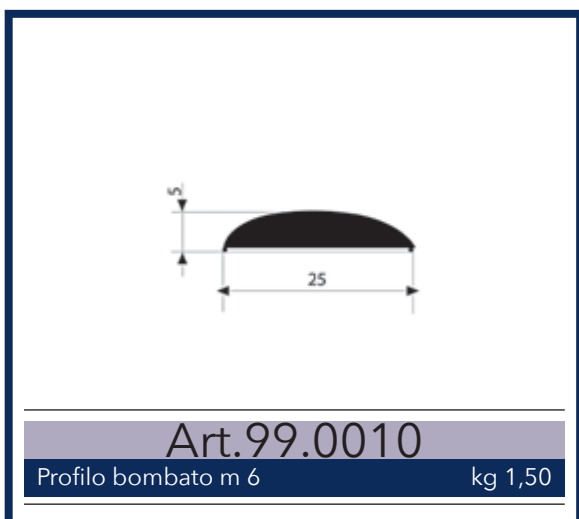
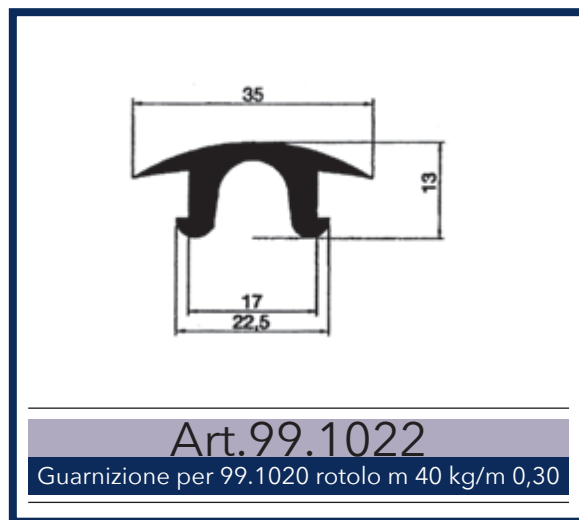
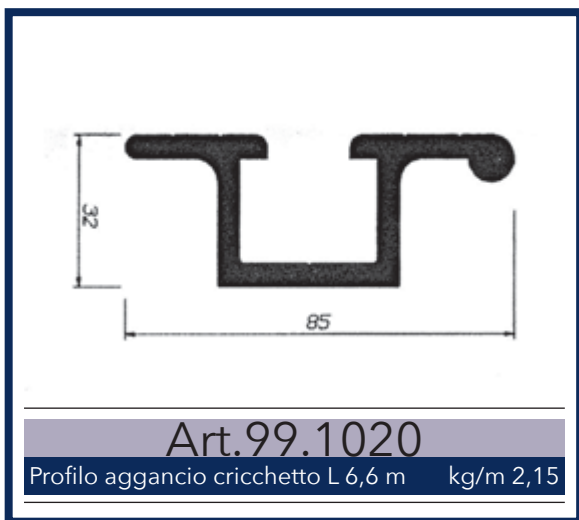

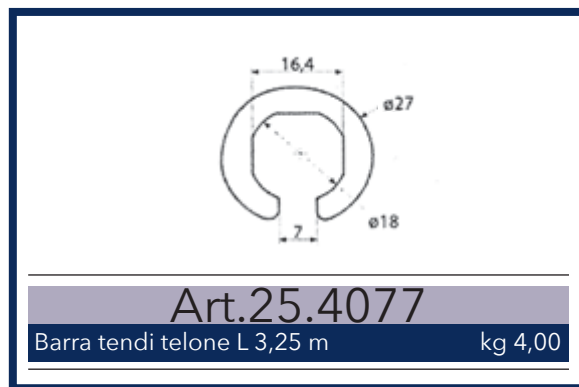
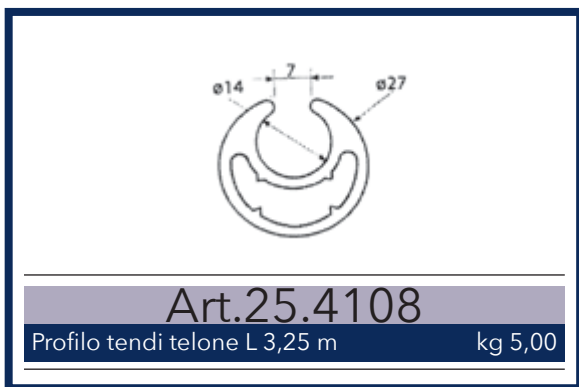
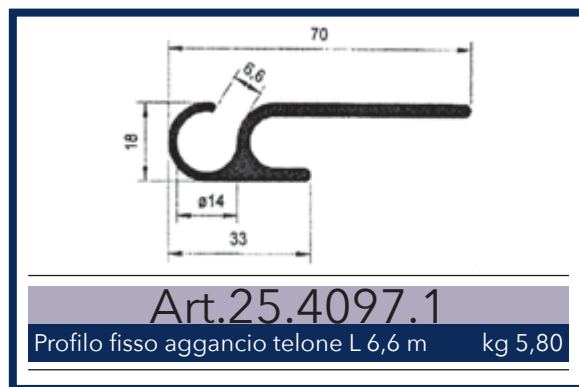
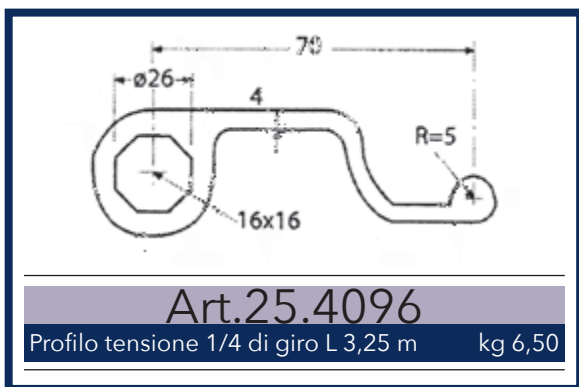
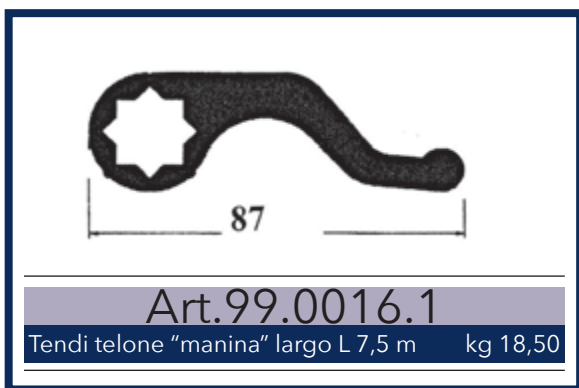
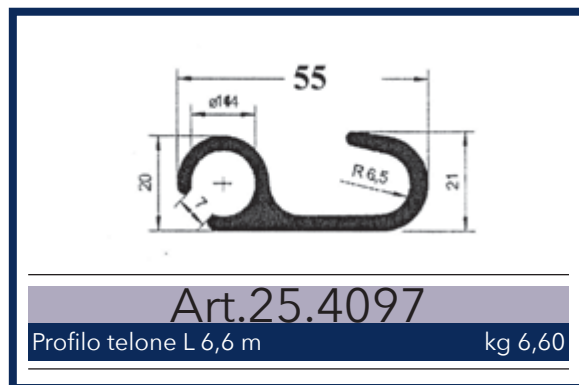
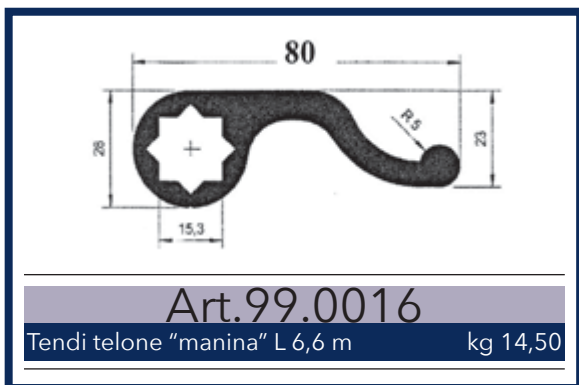

PROFILI TENDITELONE

LONGHERINA LATERALE CON SCALINO

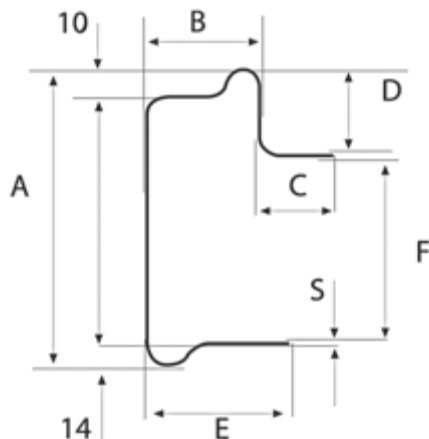

	kg/m	L	S	A	B	C	D	E	F	Acciaio
<b>Art.32.0220</b>	7,80	6800	3,50	155	50	24	31	50	102	Grezzo
<b>Art.32.0222</b>	7,80	8300	3,50	155	50	24	31	50	102	Grezzo
<b>Art.32.0224</b>	6,80	9600	3,00	155	50	24	31	43	102	<b>Inox</b>

LONGHERINA LATERALE

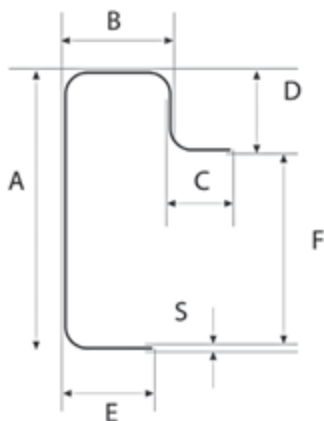

	kg/m	L	S	A	B	C	D	E	F	Acciaio
<b>Art.32.0200</b>	2,80	6500	2,00	81	50	26	15	22	62	Grezzo
<b>Art.32.0202</b>	2,90	6500	2,00	84	50	27	18	22	62	Grezzo
<b>Art.32.0206</b>	7,75	6500	4,00	116	50	40	27	43	81	Grezzo
<b>Art.32.0208</b>	9,17	6500	4,00	141	50	50	31	50	102	Grezzo

LONGHERINA LATERALE IN ACCIAIO GREZZO SAGOMATA CON SEDE AGGANCIO FERMACARICO

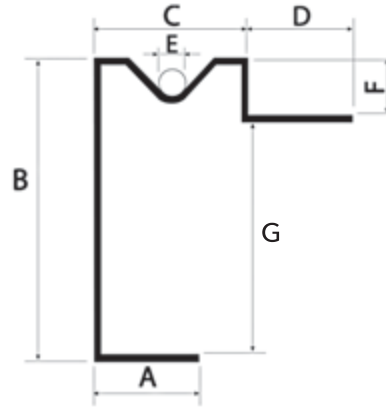

	kg/m	L	A	B	C	D	E	F	G	Spess.
<b>Art.32.0228</b>	2,80	6500	22	90	60	26	10	15	71	20/10
<b>Art.32.0230</b>	2,80	6500	22	93	60	26	10	18	71	20/10
<b>Art.32.0232</b>	4,50	6500	30	109	65	30	10	21	82	30/10

Su ordinazione

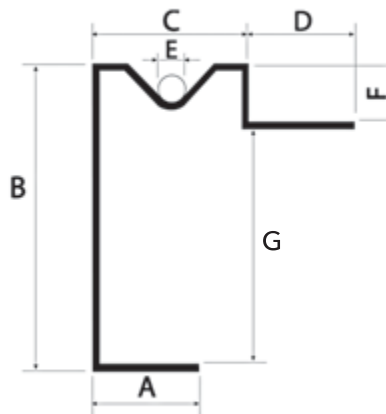

	kg/m	L	A	B	C	D	E	F	G	Spess.
<b>Art.32.0234</b>	7,60	6500	30	116	65	30	10	24	86	30/10
<b>Art.32.0236</b>	8,80	6500	35	120	65	30	10	27	86	30/10

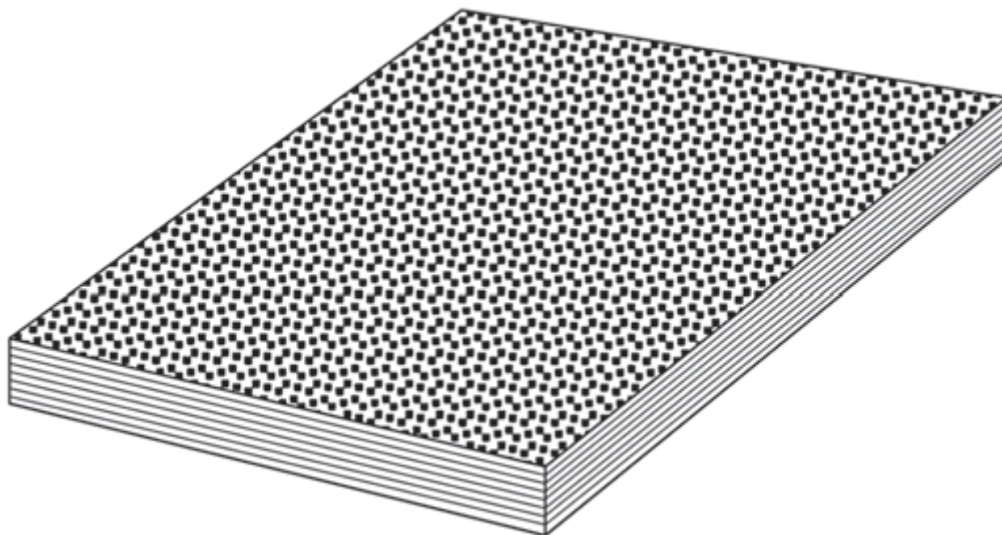

### WISA WIRE

SPESSORE

Formato mm	12	15	18	21	24	27	30	35
1525x2150		32.1056	32.1058					
Peso		36,5	44,0					
1525x2500	32.1040	32.1042	32.1044	32.1046	32.1048	32.1050	32.1052	32.1054
Peso	33,0	38,0	51,0	54,0	62,0	71,0	76,0	92,0
1250x2500	32.1060	32.1062	32.1064	32.1066	32.1068	32.1070	32.1072	32.1074
Peso	27,2	31,2	41,8	44,3	50,8	58,3	62,4	75,5
1250x2150		32.1076	32.1078					
Peso		26,7	35,8					

### WISA TRANS

SPESSORE

Formato mm	12	15	18	21	24	27	30	35
1525x2500					32.1049	32.1051	32.1053	32.1055
Peso					64,0	71,0	79,0	99,0

### WISA TRUCK PLUS

SPESSORE

Formato mm	12	15	18	21	24	27	30	35
2350x1220					32.10754		32.1075	
Peso					61,0		77,0	

### WBP

SPESSORE

Formato mm	9	12	15	18	21	24	27	30	35
1530x2150			32.1096	32.1098					
Peso			44,0	42,0					
1530x2500	32.1080	32.1081	32.1083	32.1085	32.1087	32.1089	32.1091	32.1093	32.1094
Peso	25,0	33,0	38,0	46,00	54,0	62,0	71,0	79,0	90,0

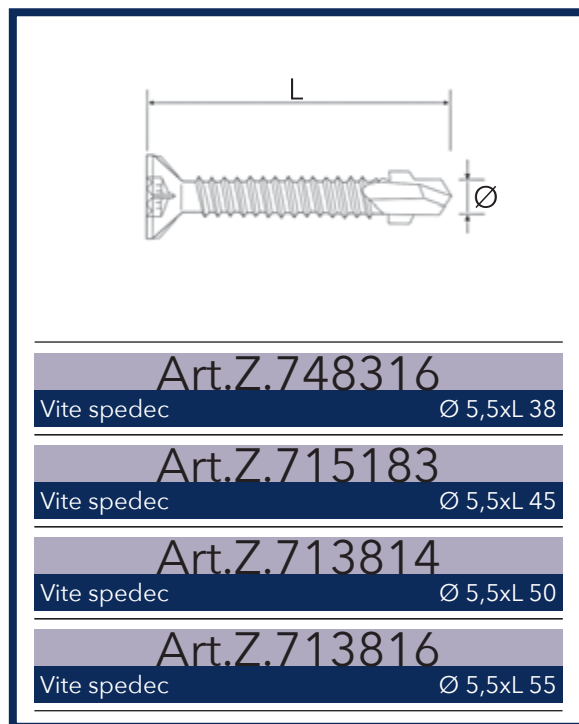
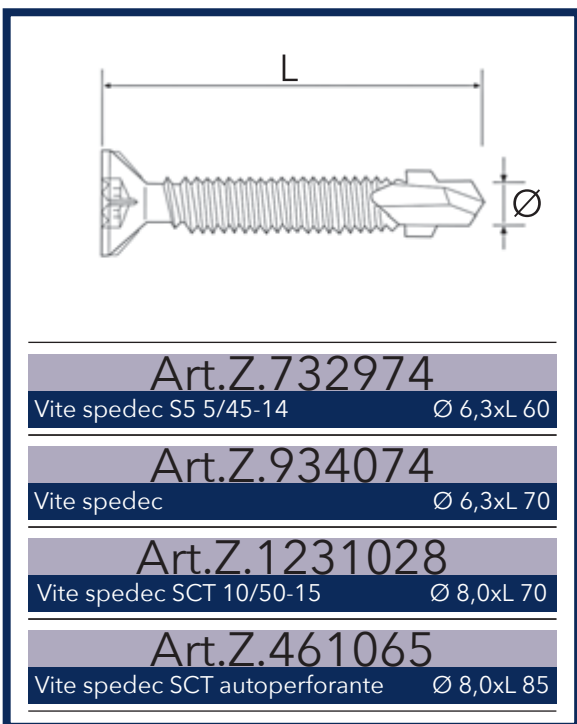
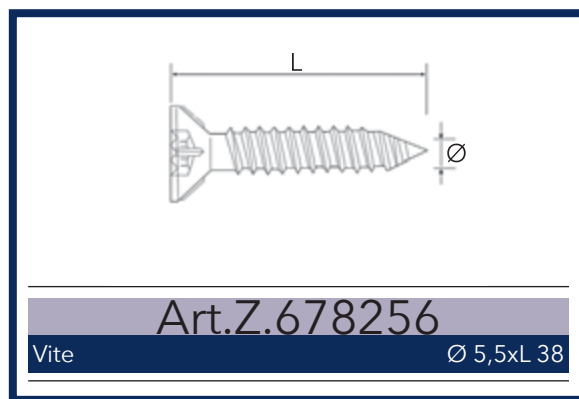
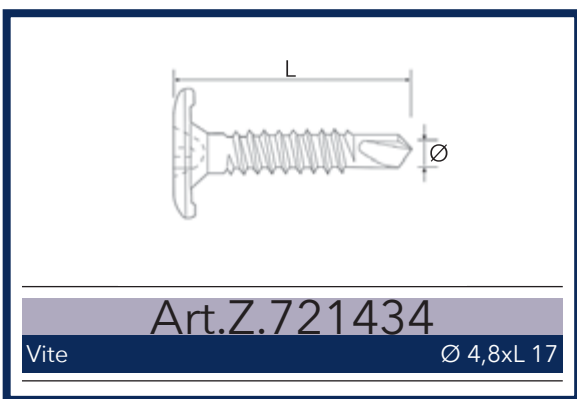

VITI PER MULTISTRATO



RIVETTI A TESTA LARGA IN ALLUMINIO

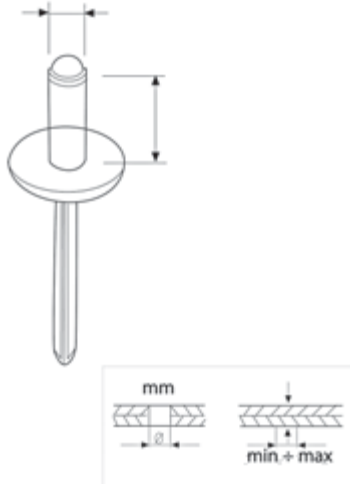

RIVETTI IN ALLUMINIO

D	L	Ø	Spessore lamiera
4,8	16	5	10÷12
	18		12÷14
	20		14÷16

RIVETTI "GRAF" ALLUMINIO

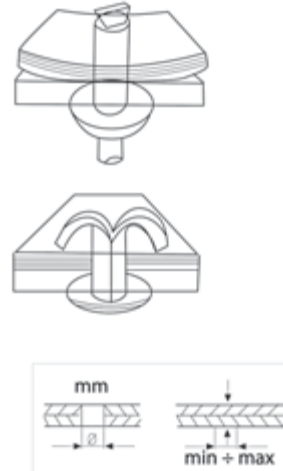

RIVETTI "GRAF" IN ALLUMINIO

D	L	Ø	Spessore lamiera
4,8	16	5	5÷10
	20		10÷14
	40		27÷32
	50		37÷42

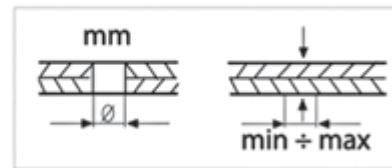
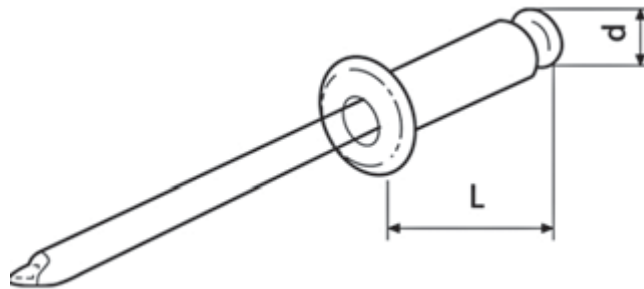

RIVETTI IN ALLUMINIO

D	L	Ø	Spessore lamiera
4,8	12	5	7÷8
	16		10÷12
	18		12÷14
	20		14÷16
6	12	6,1	5÷7
	15		7÷10
	18		10÷13
	22		13÷17
6,4	12	6,5	5÷7
	15		7÷10
	18		10÷13
	22		13÷17

RIVETTI IN ACCIAIO ZINCATO

D	L	Ø	Spessore lamiera
6	12	6,1	4÷7
	15		7÷10
	6,4		12
15	7÷10		

RIVETTI IN ACCIAIO INOX

D	L	Ø	Spessore lamiera
4,8	12	5	7÷8
	16		10÷12
6	12	6,1	5÷7
	15		7÷10
6,4	12	6,55	5÷7
	15		7÷10

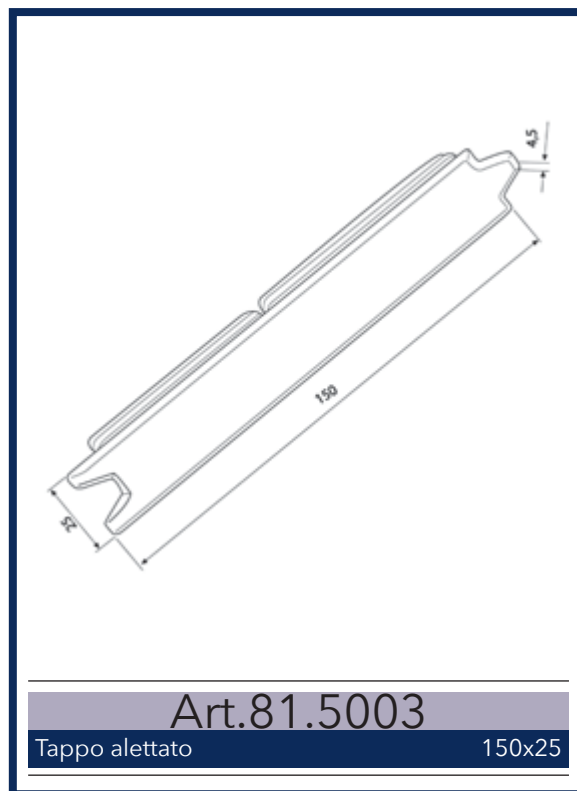
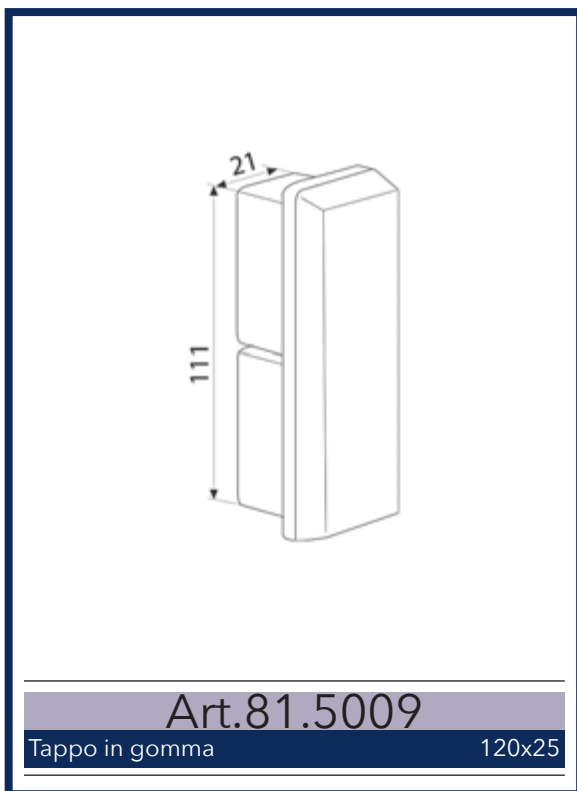
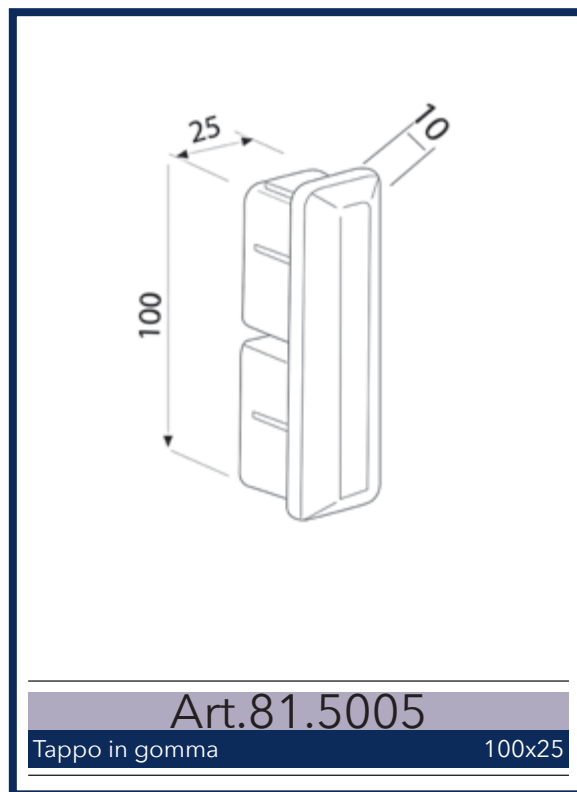
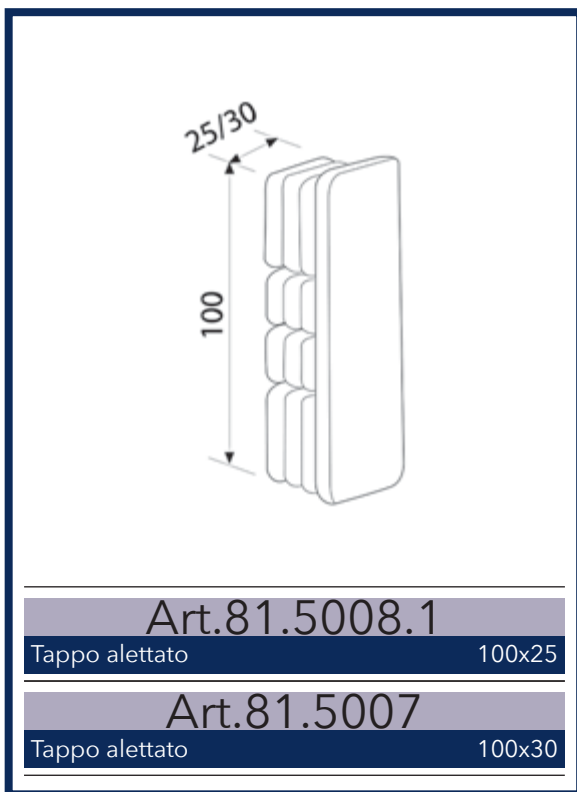

TAPPI PER PROFILI SOVRASPONDE